

**CAVITATION**

**DEPRESSION**

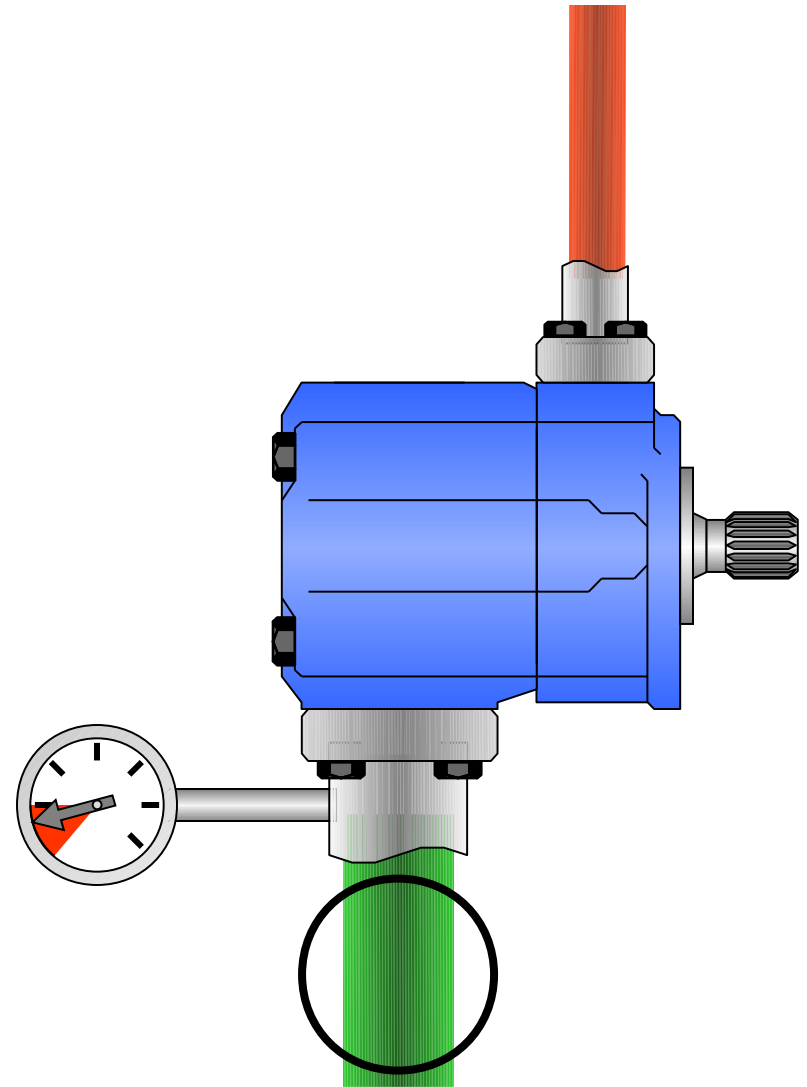

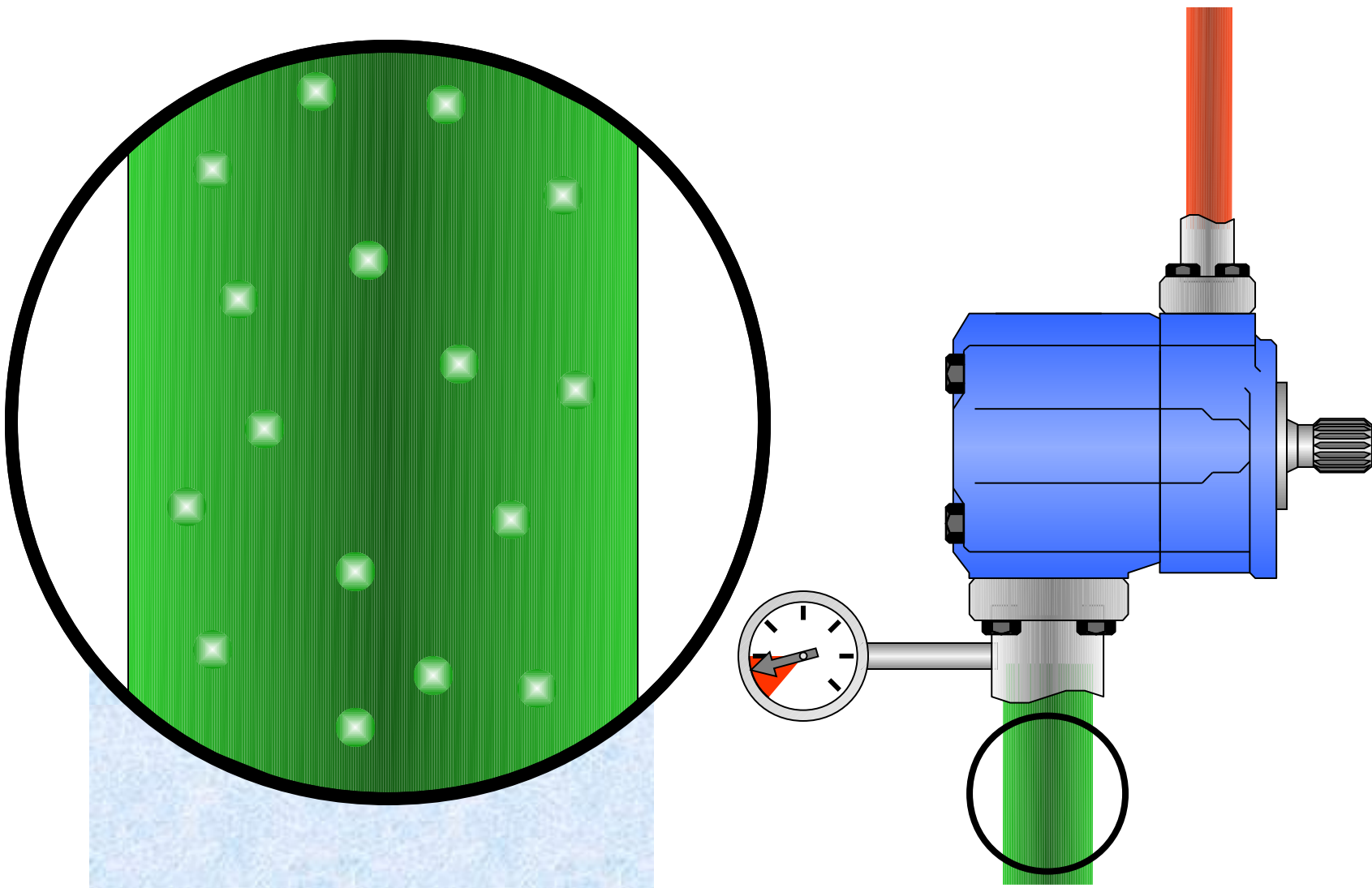

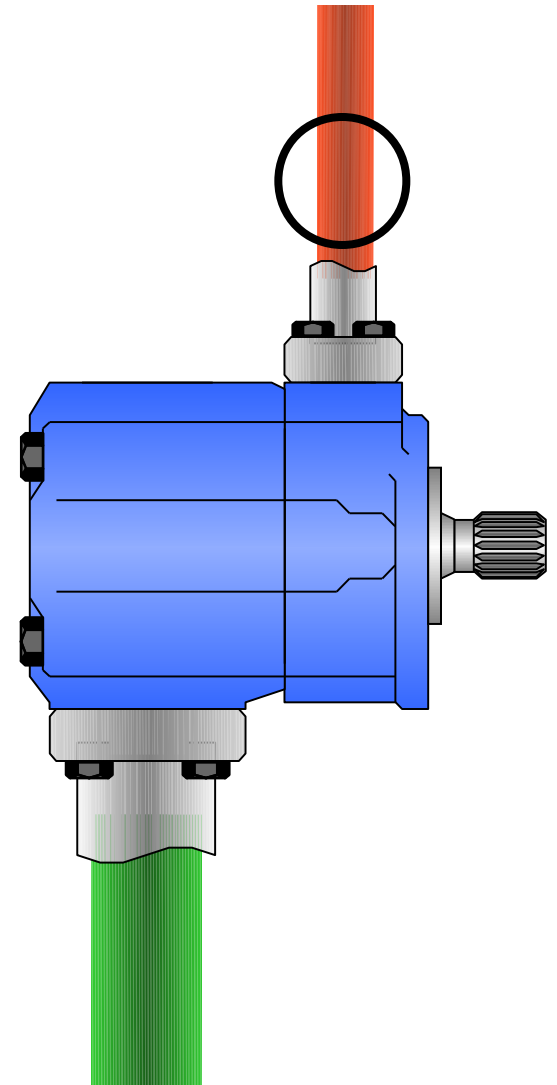
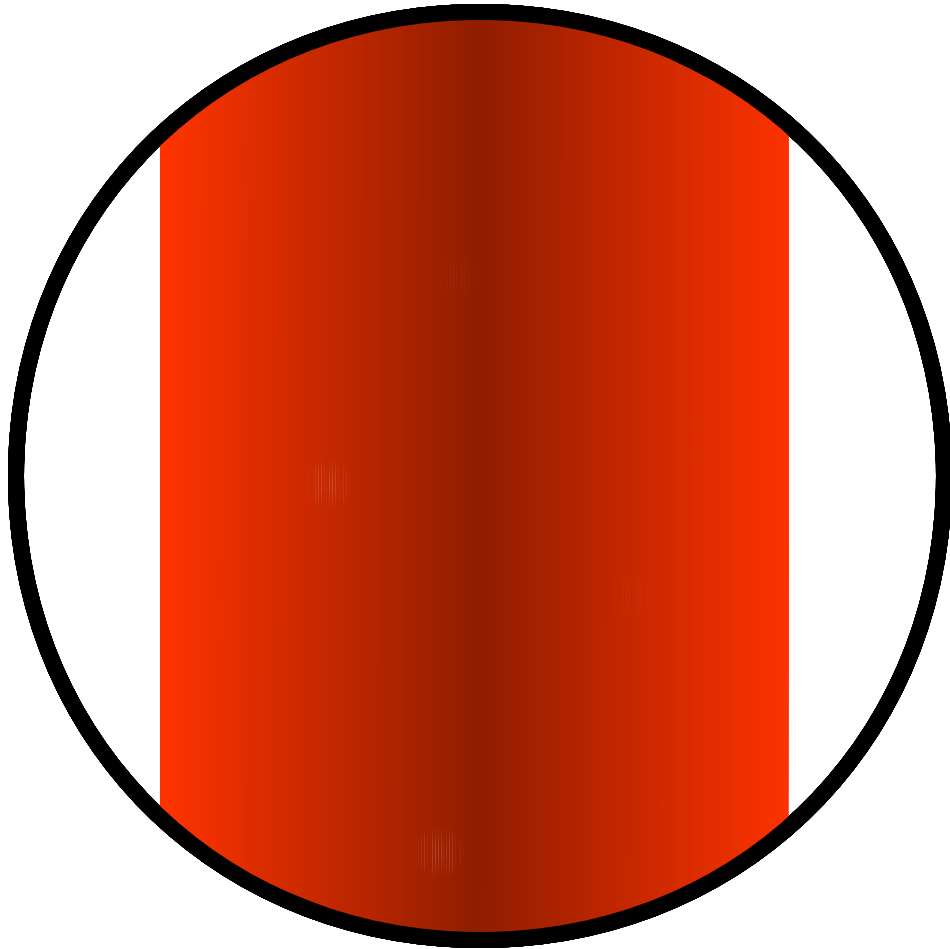



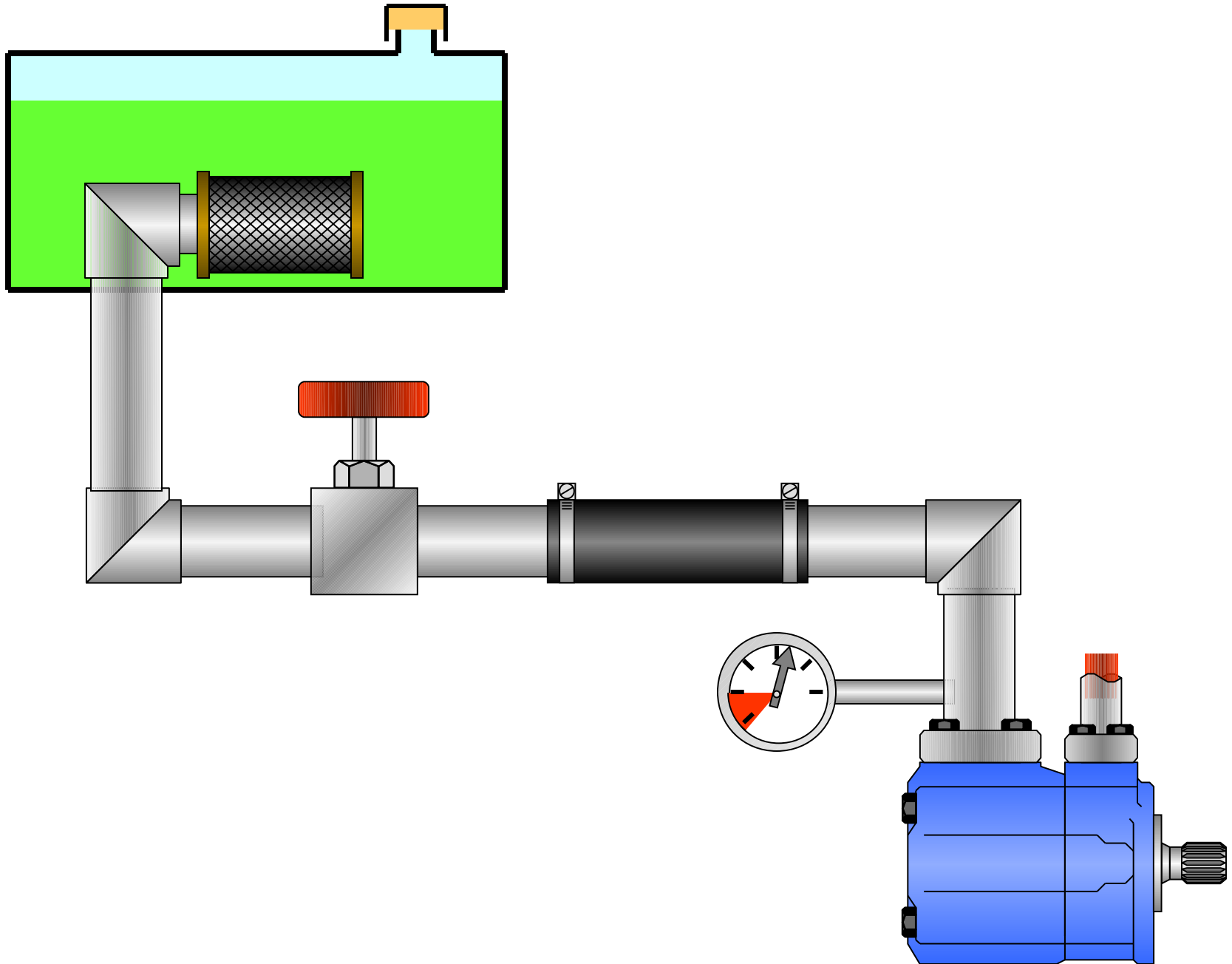

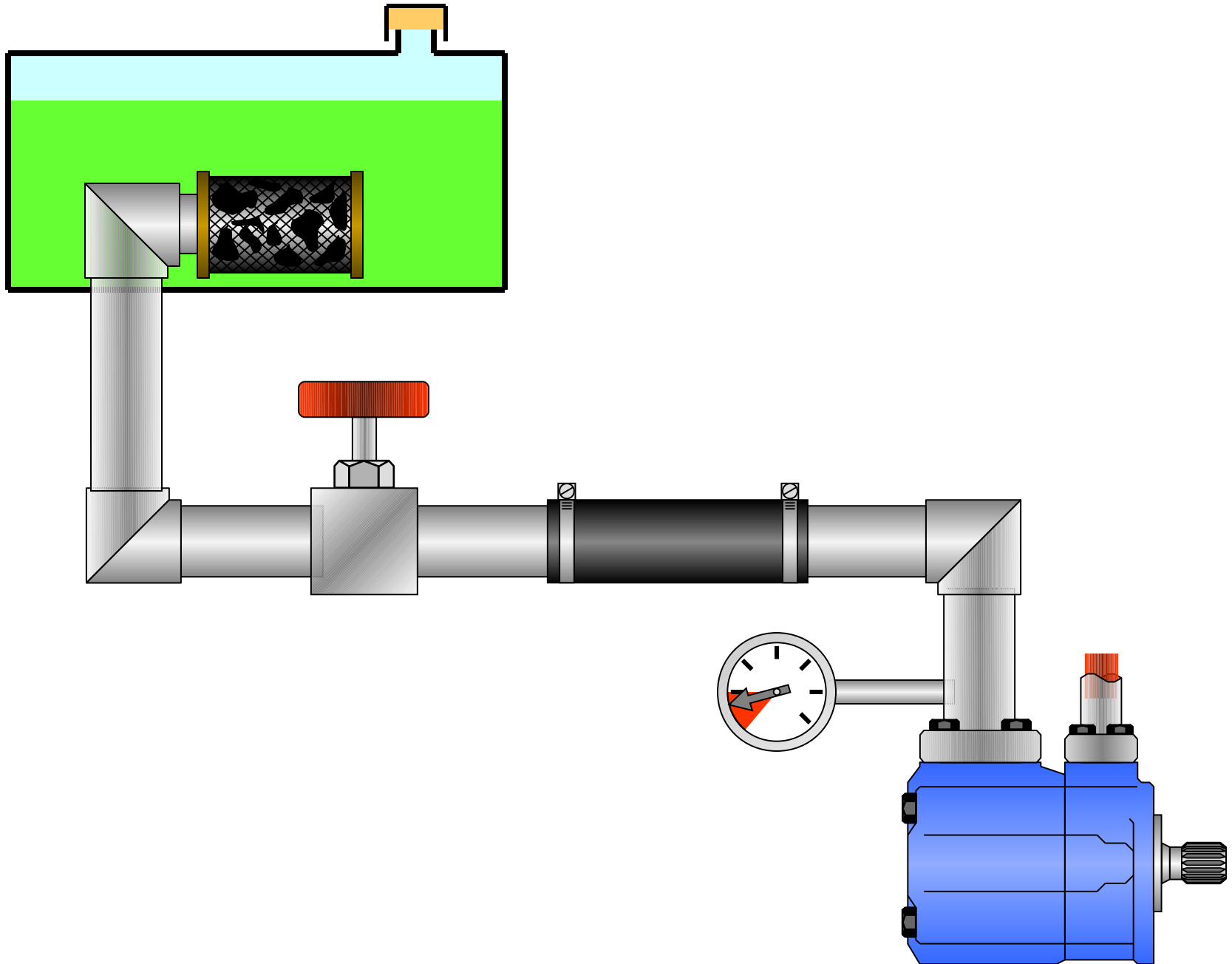



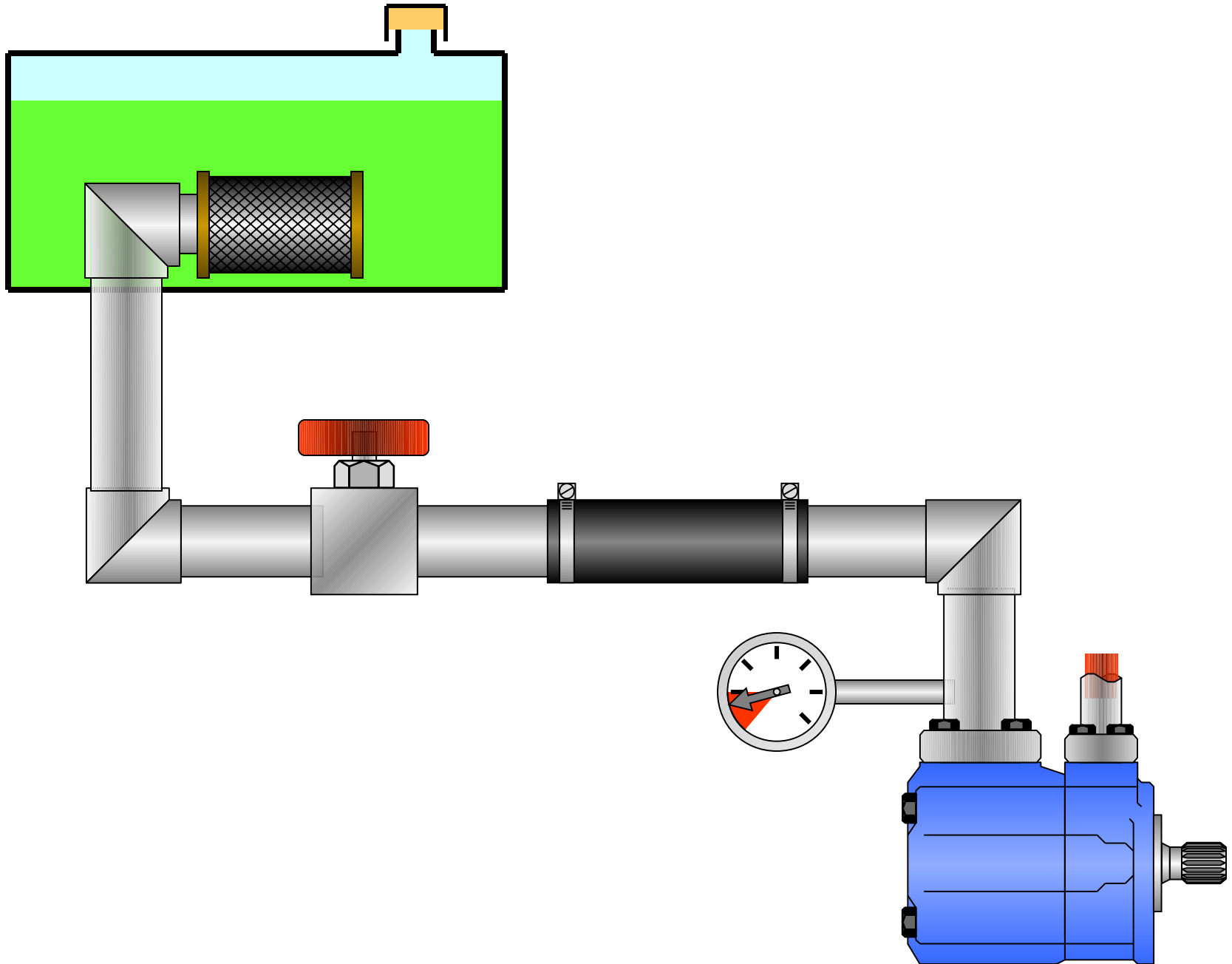

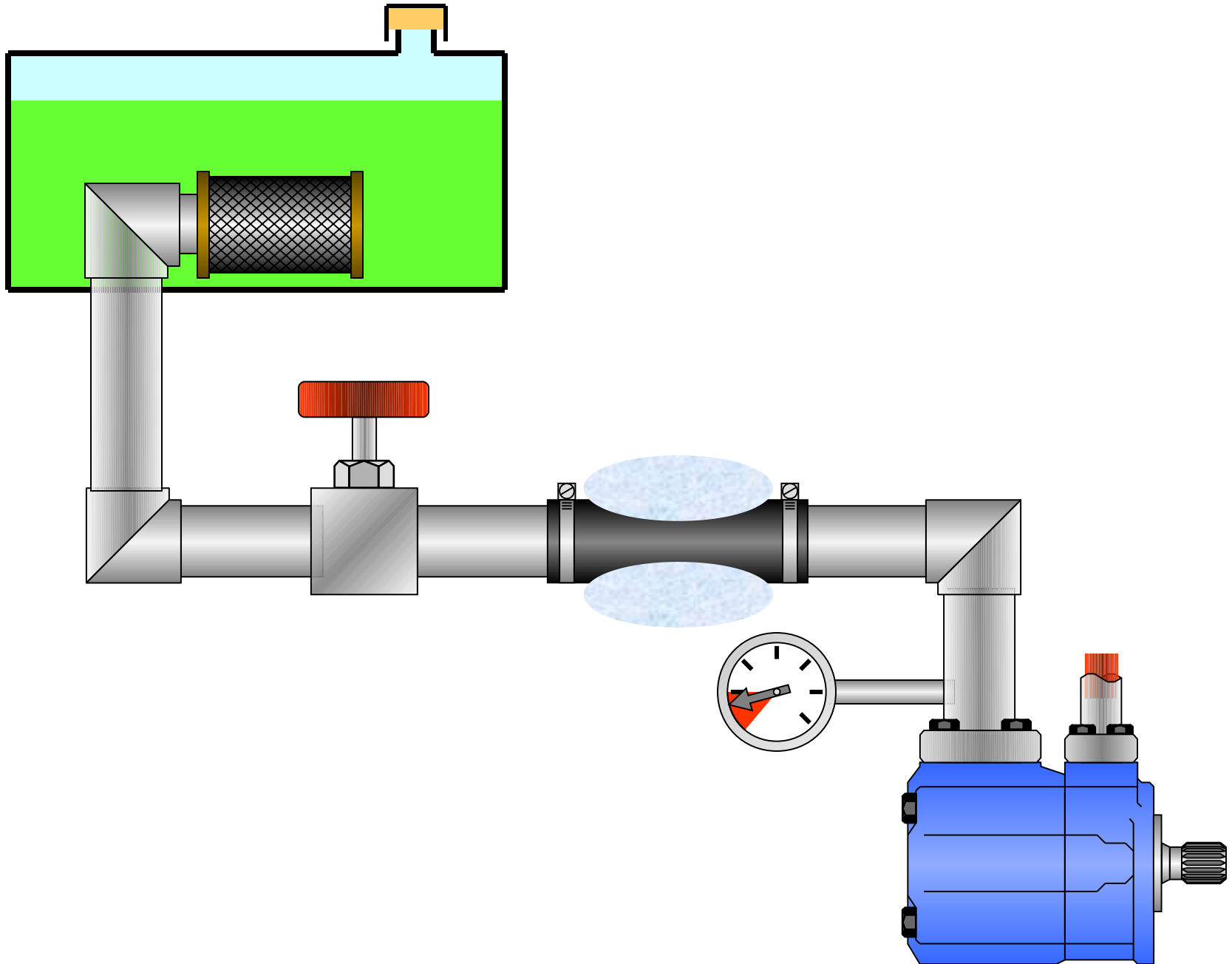

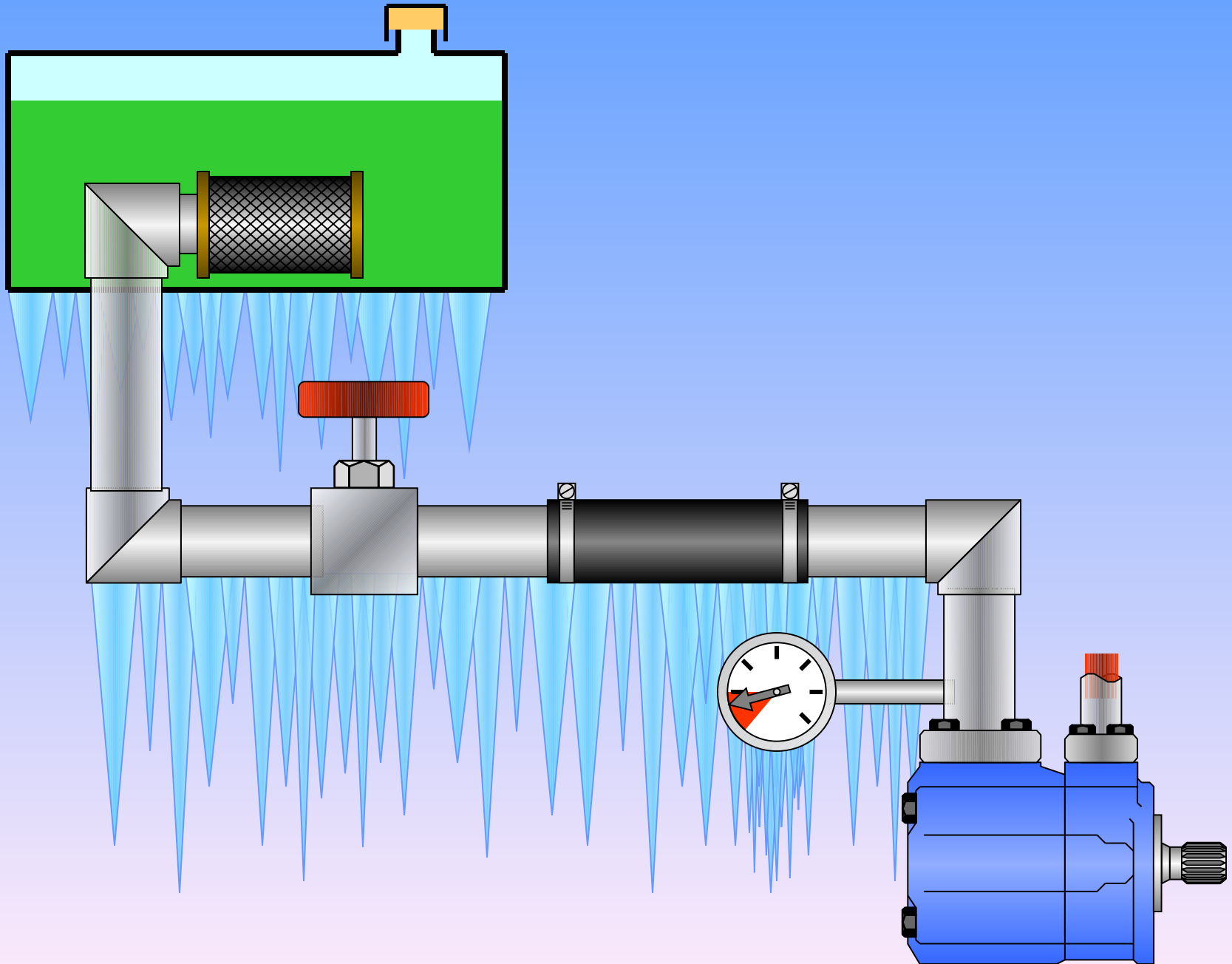

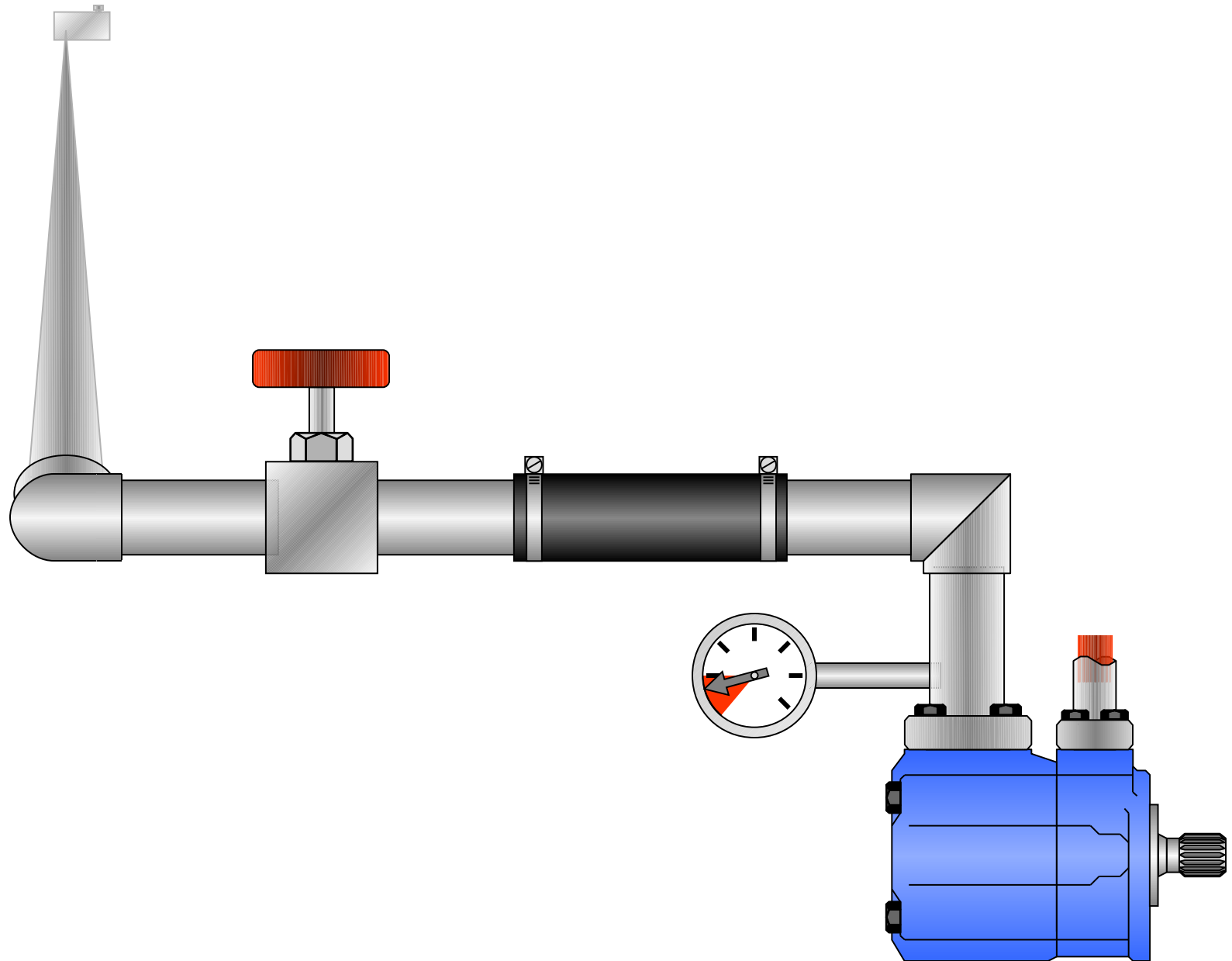

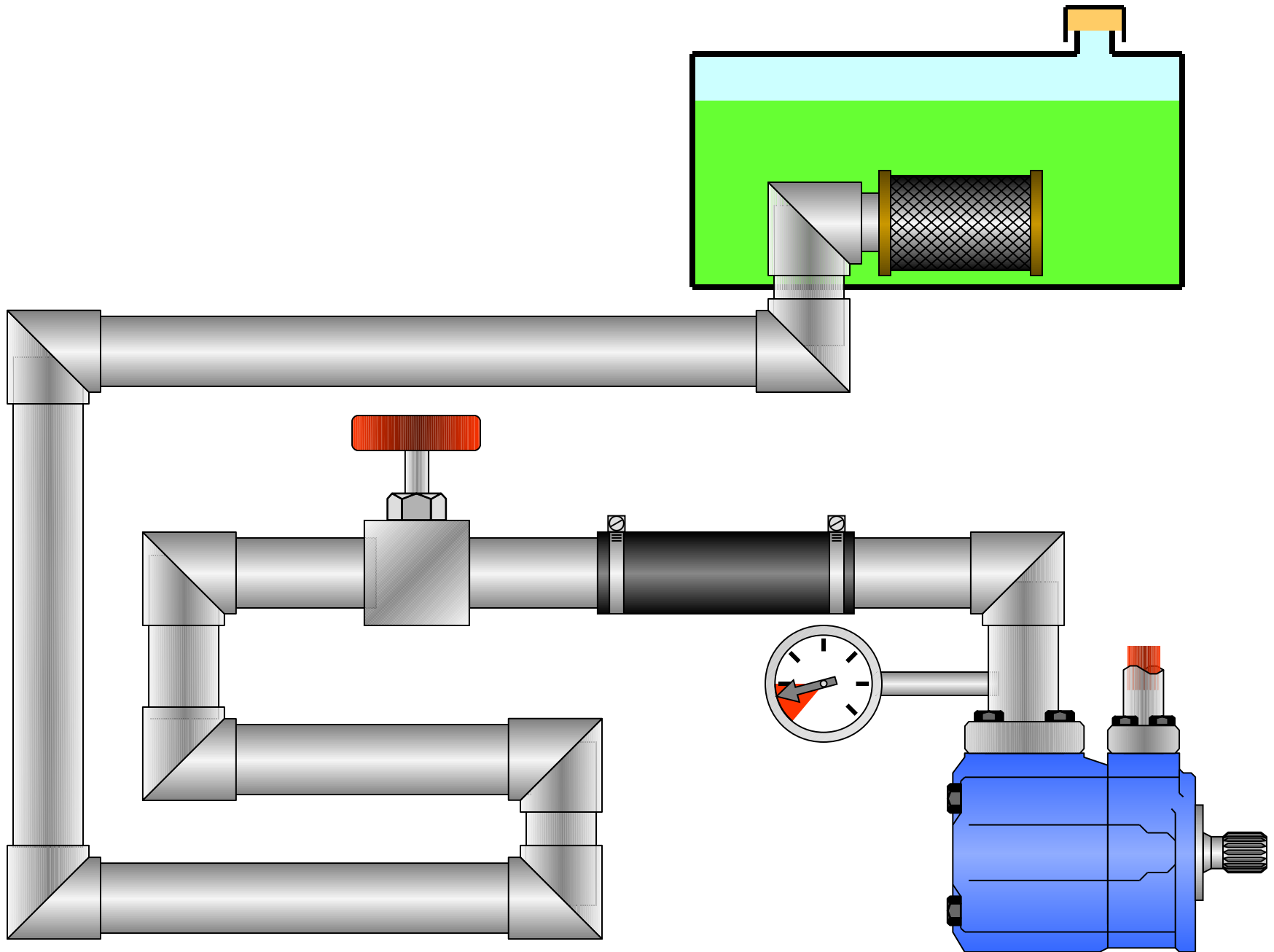

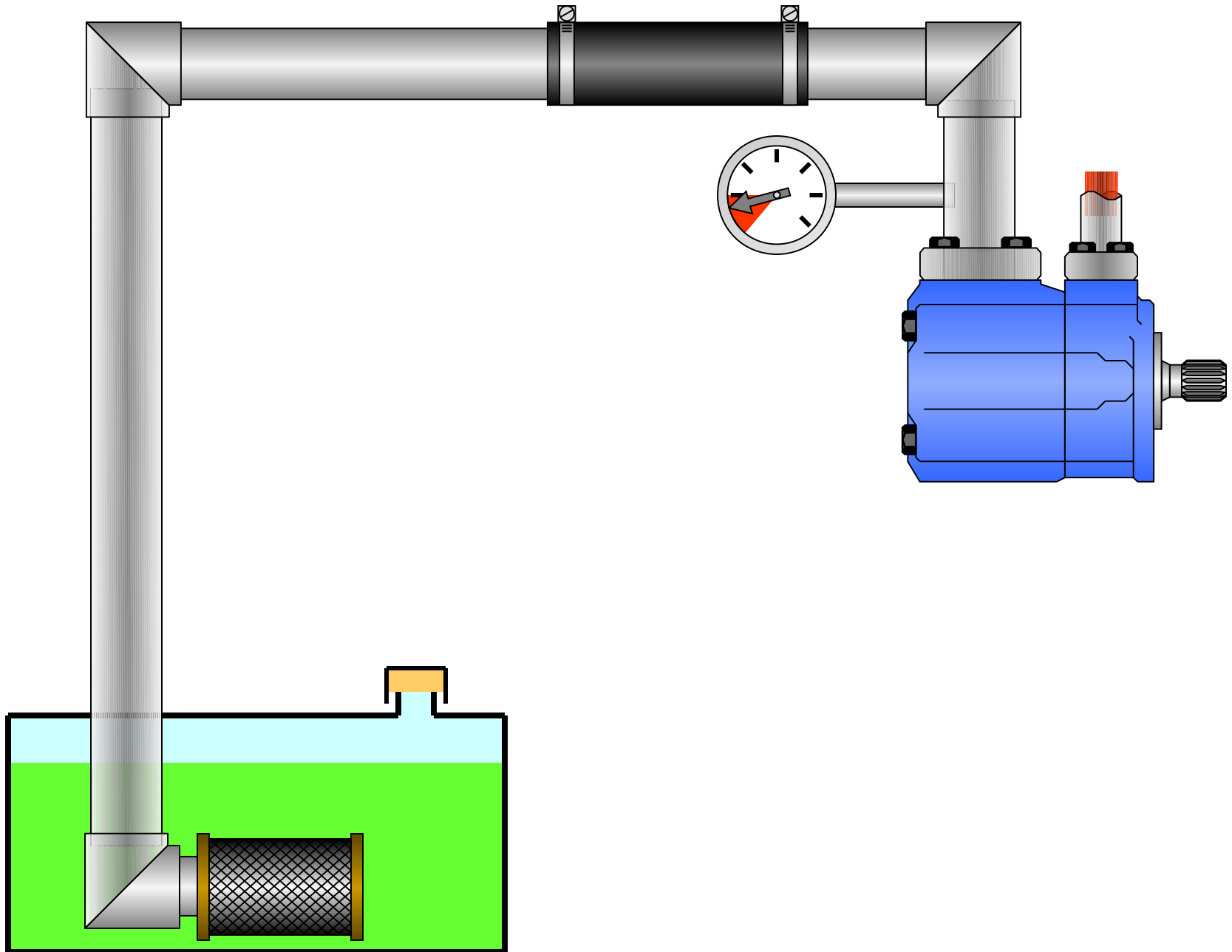

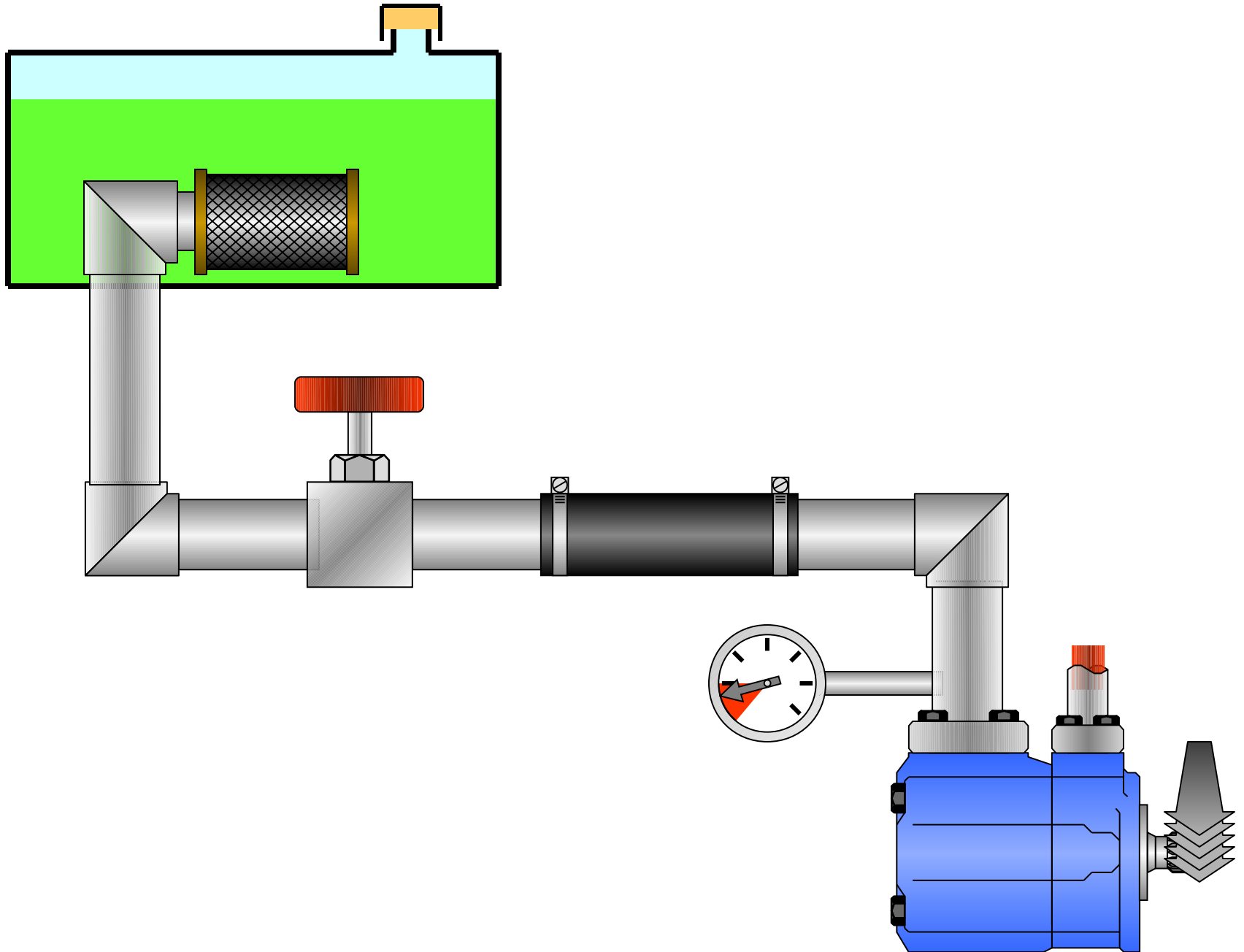

# LES CAUSES DE LA CAVITATION : LE FILTRE à AIR EST OBSTRUE

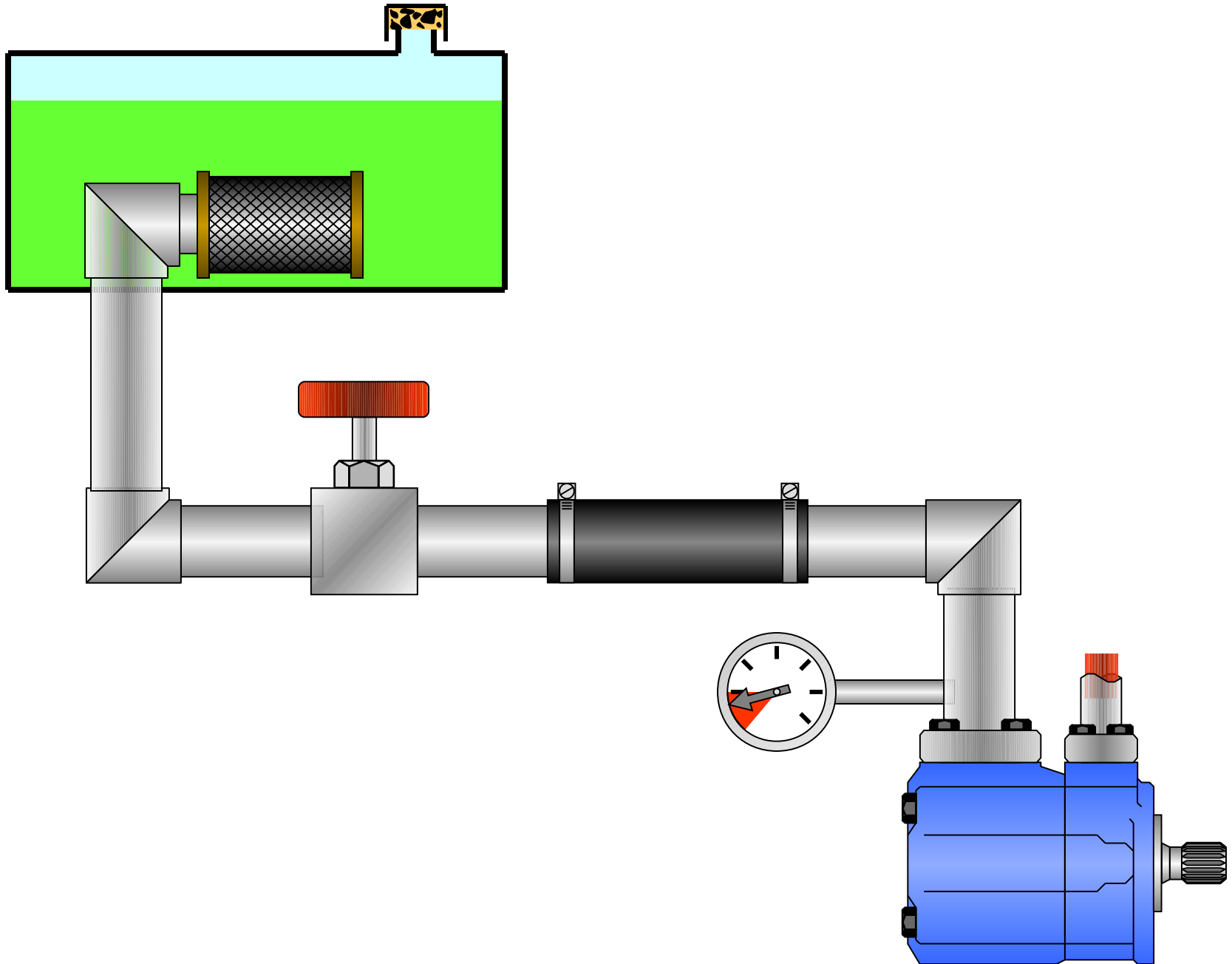



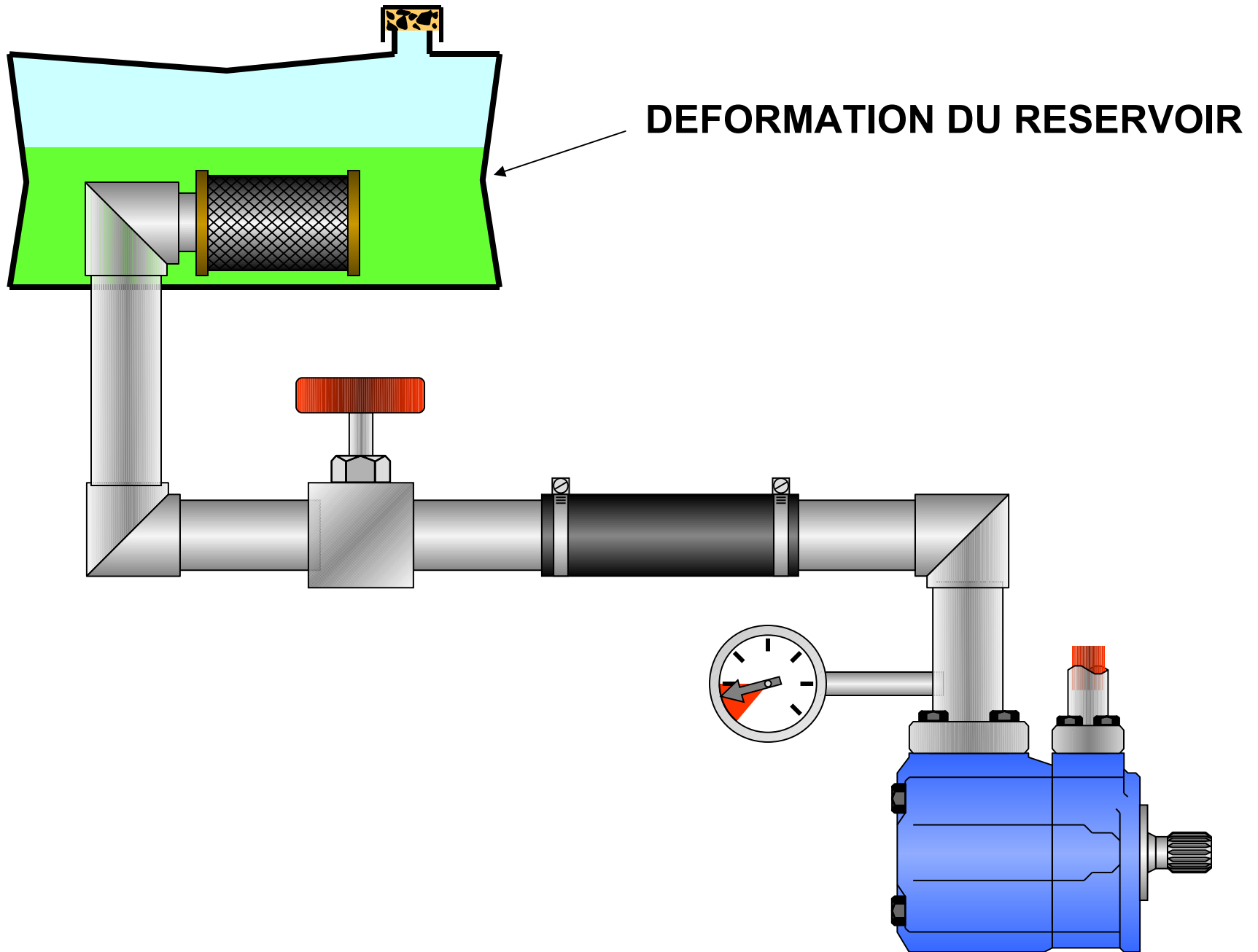

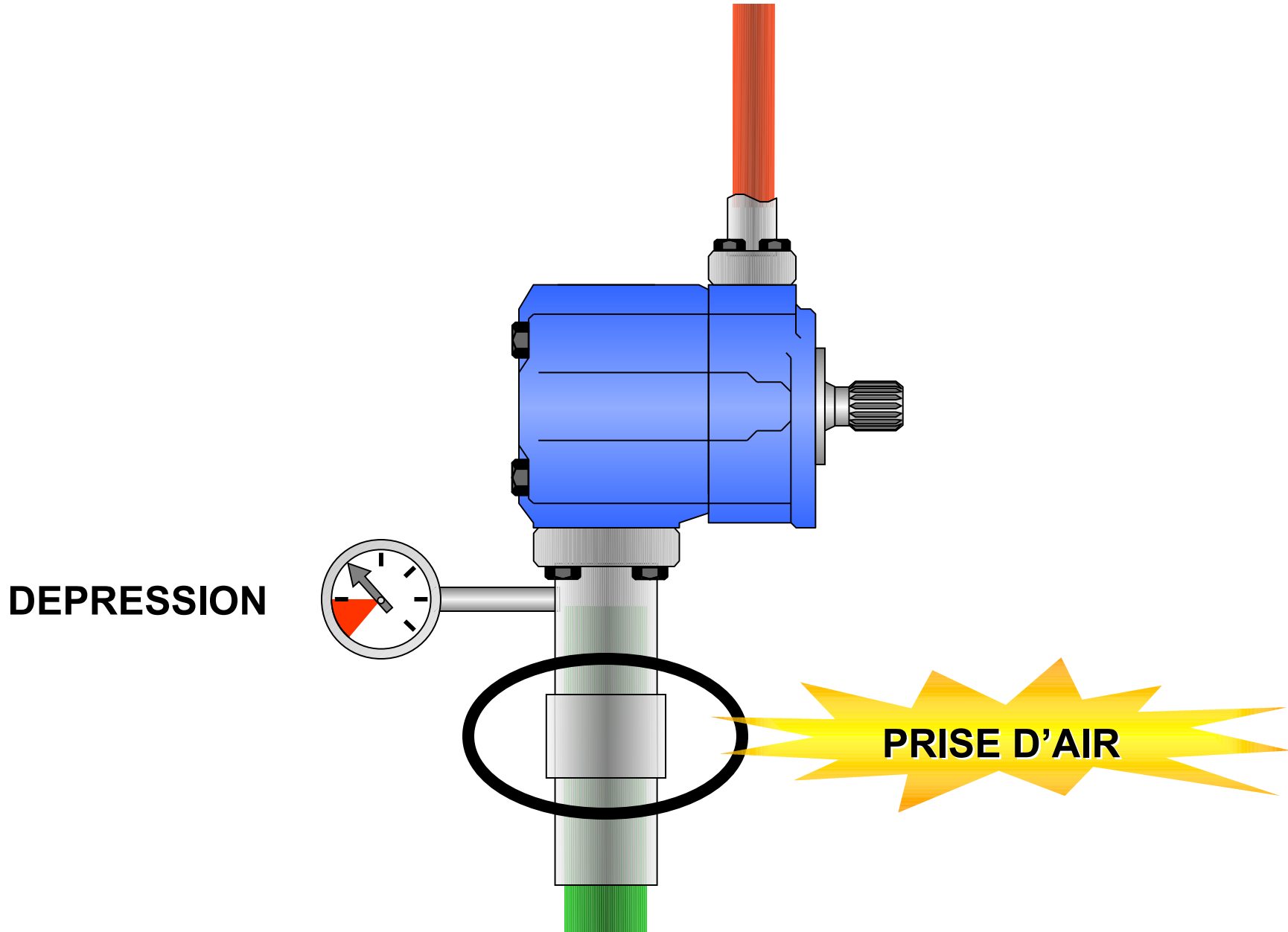

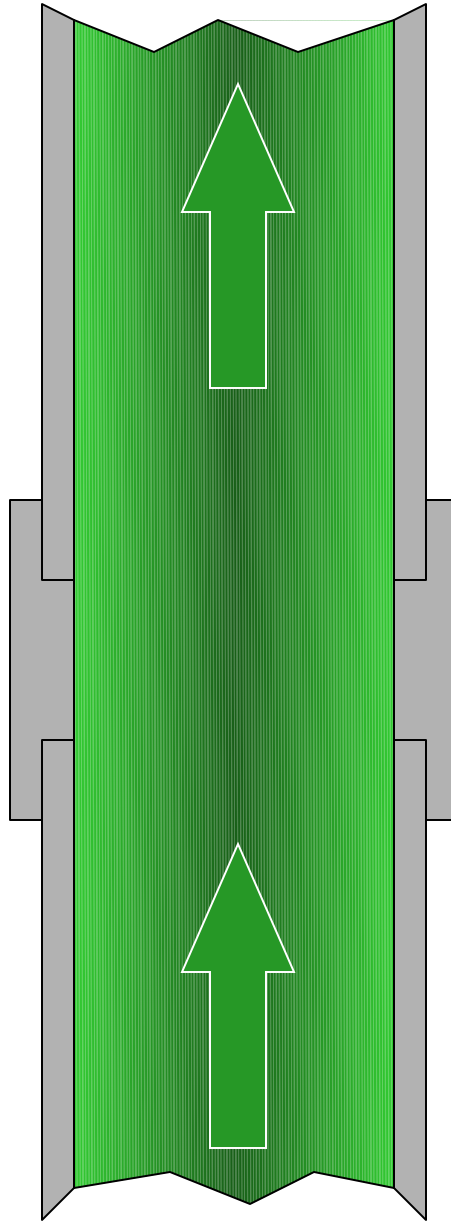

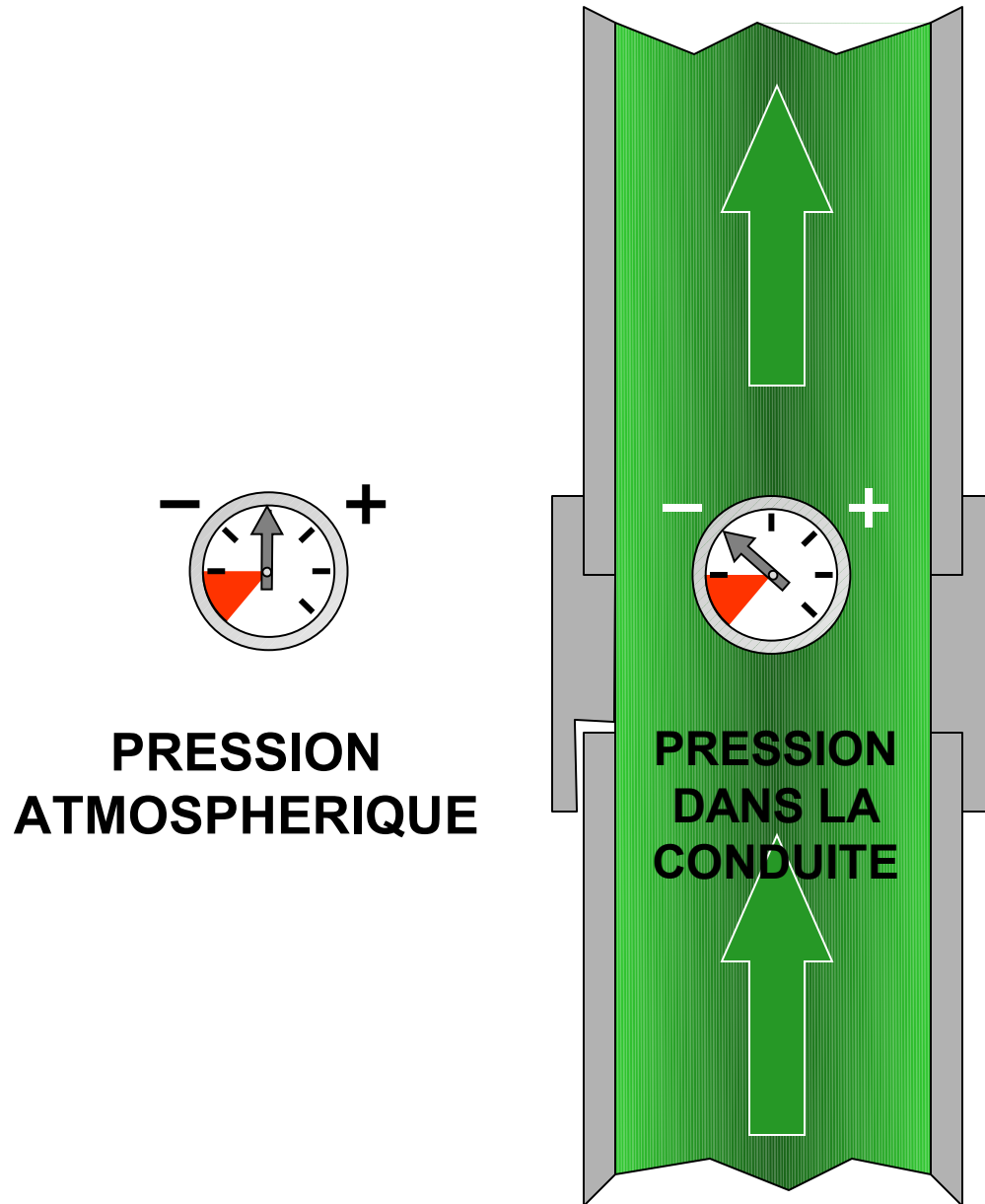

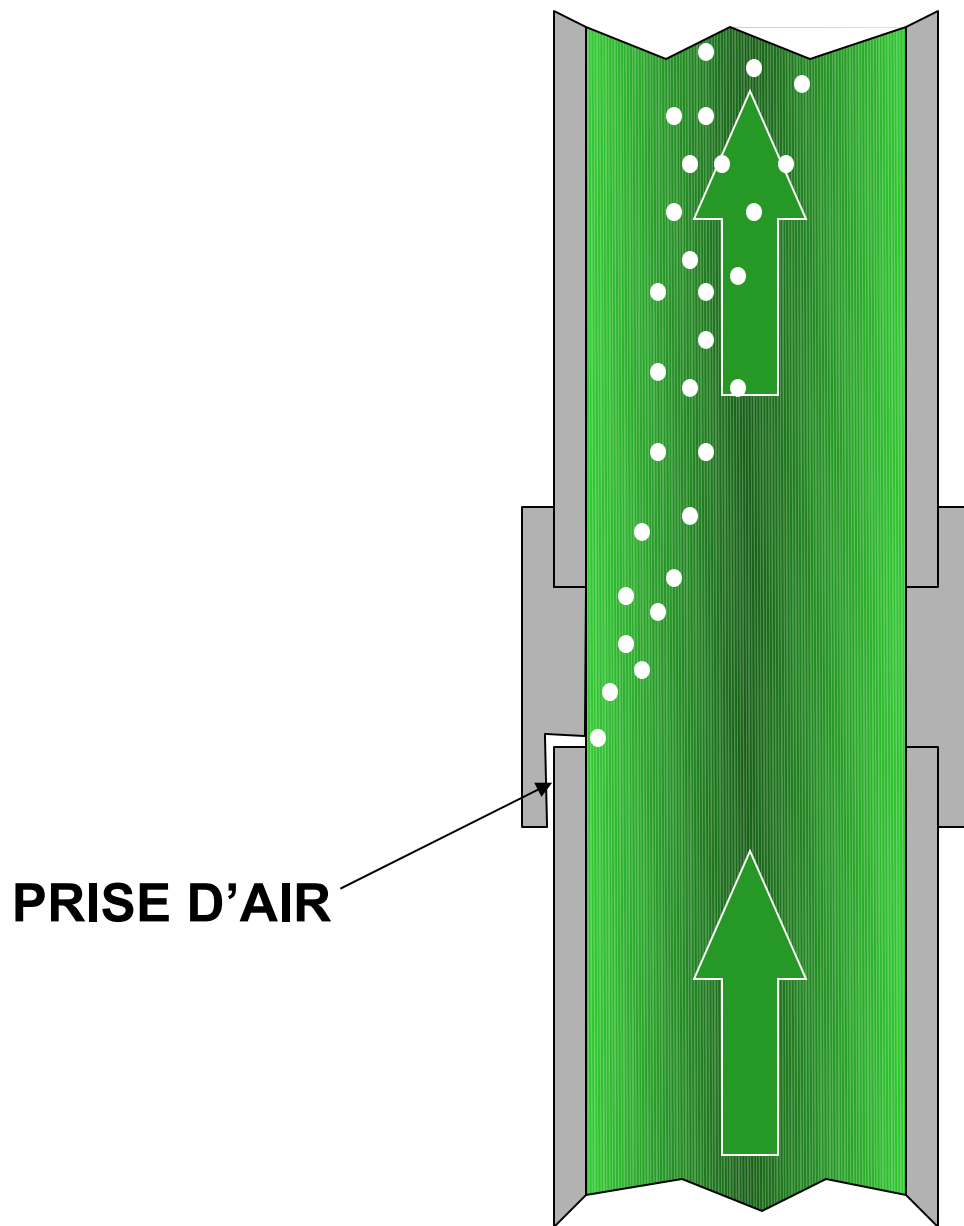

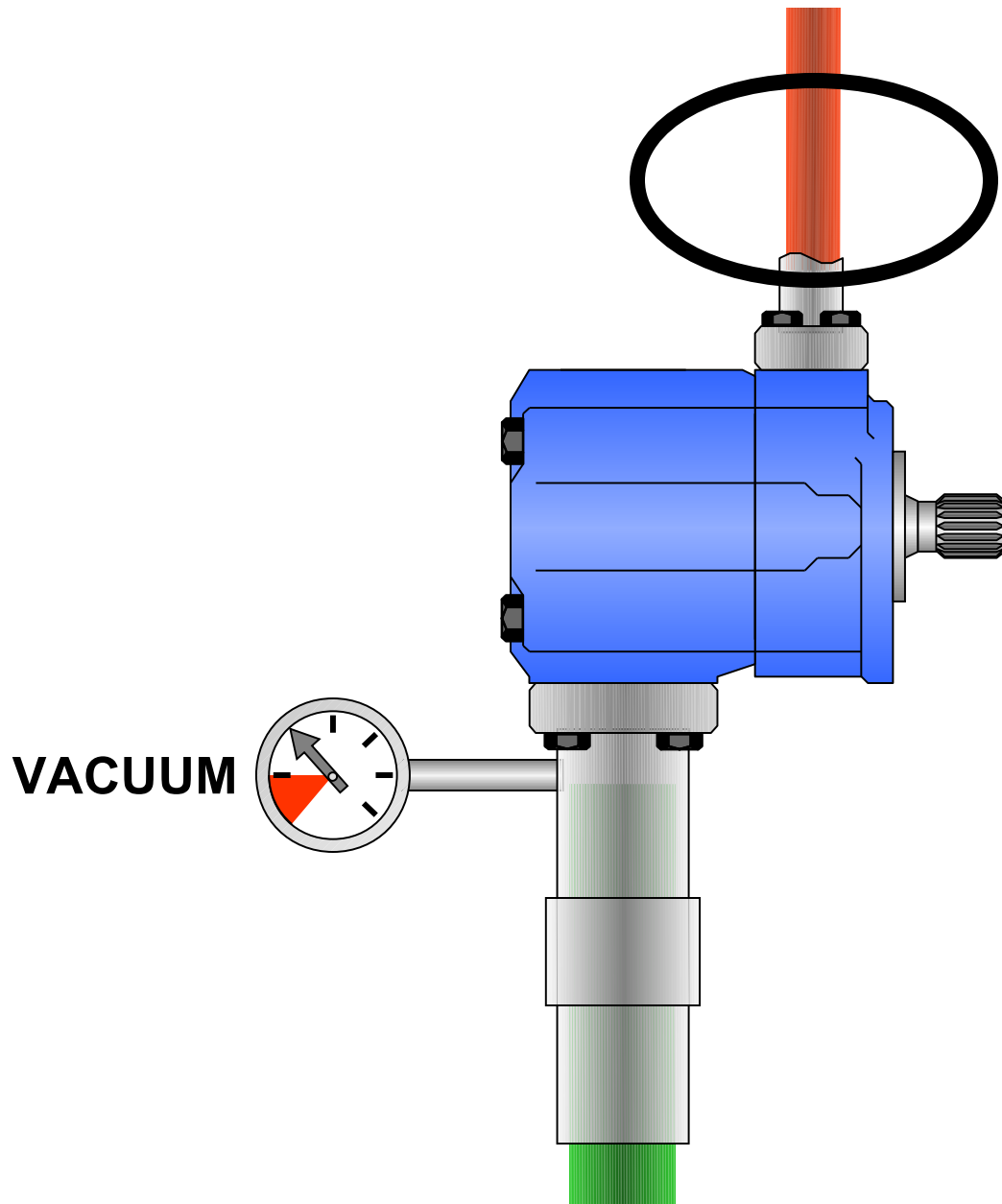

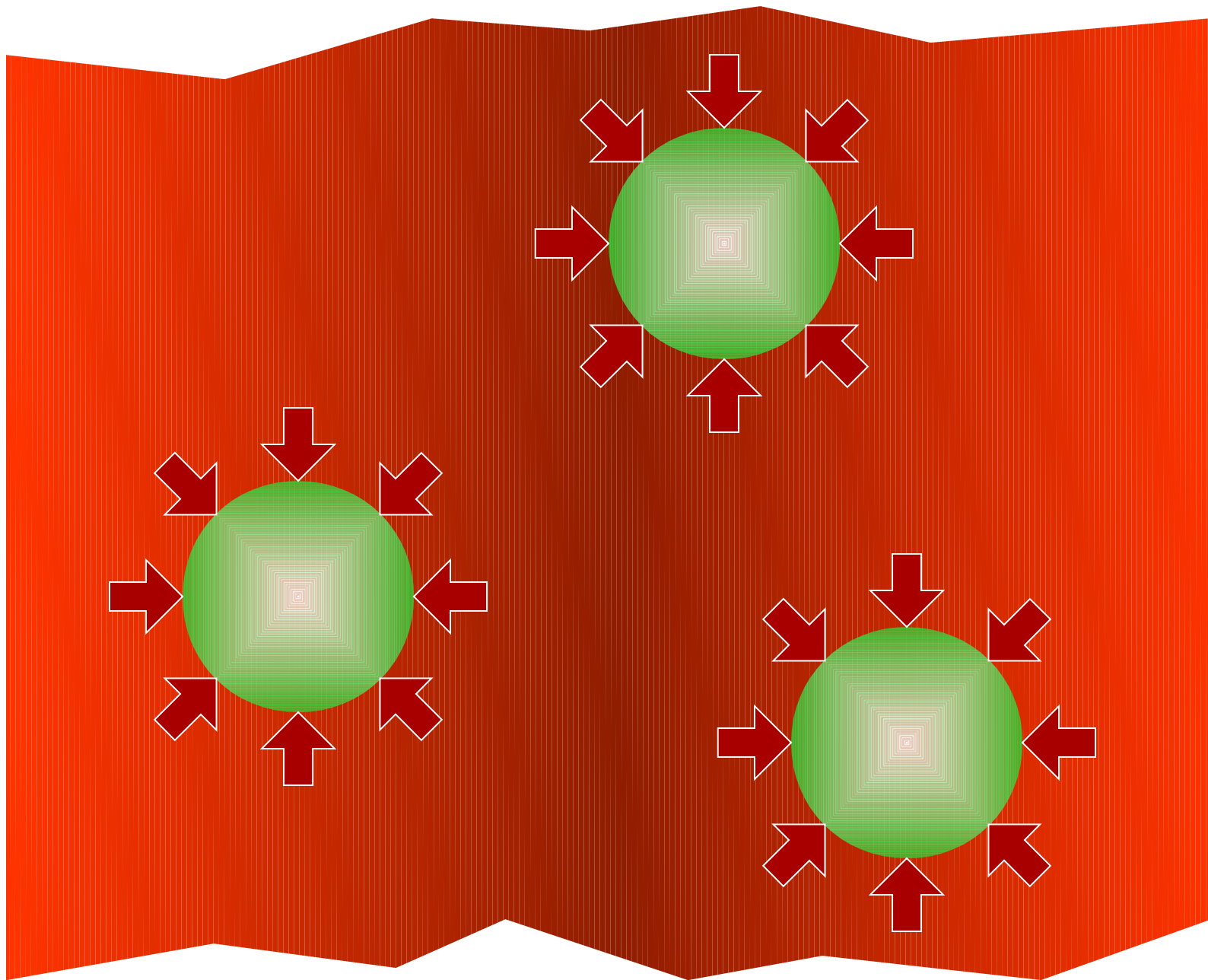

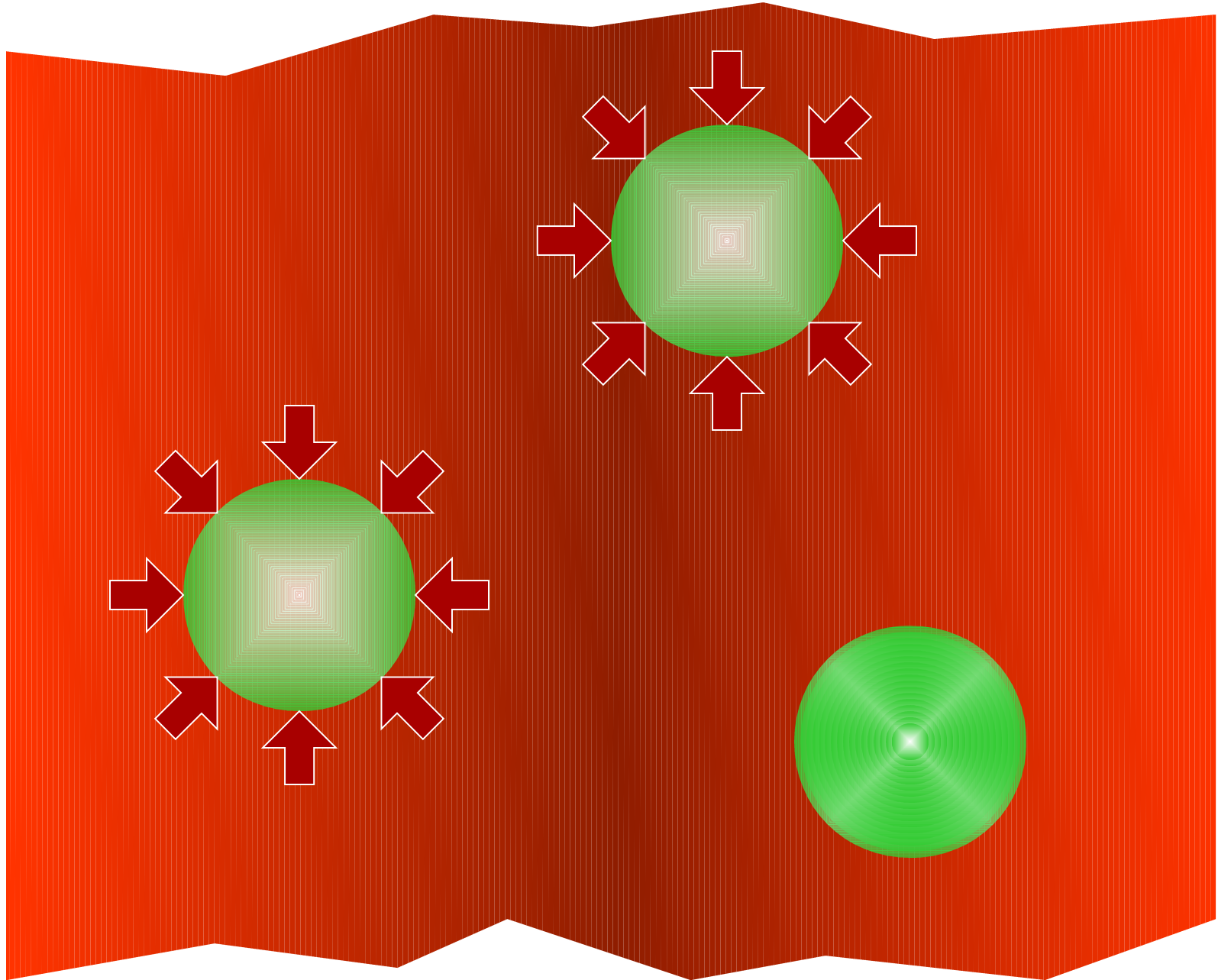



# LES BULLES D'AIR SONT COMPRIMEES : ELEVATION DE LA PRESSION **FAT•N**

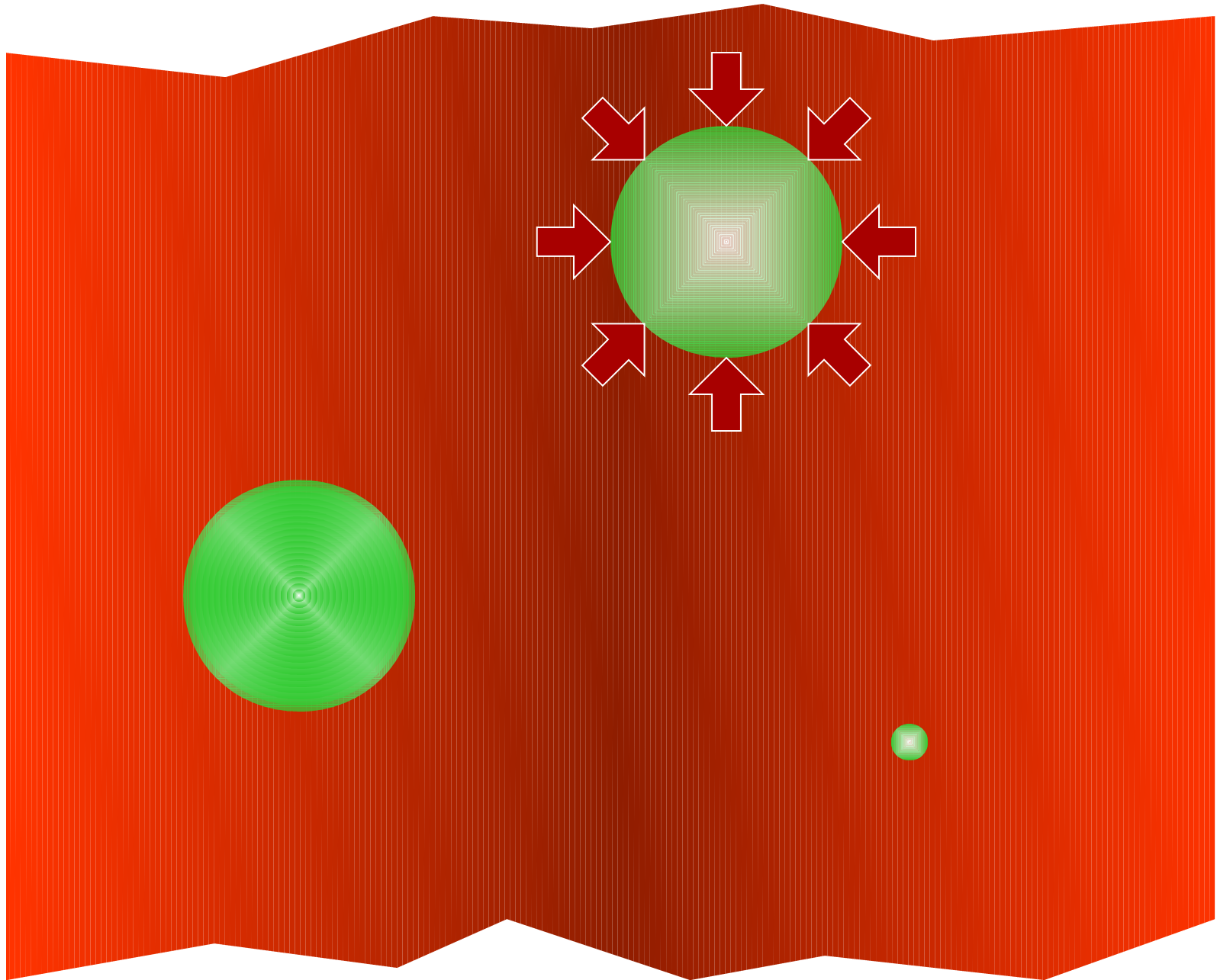

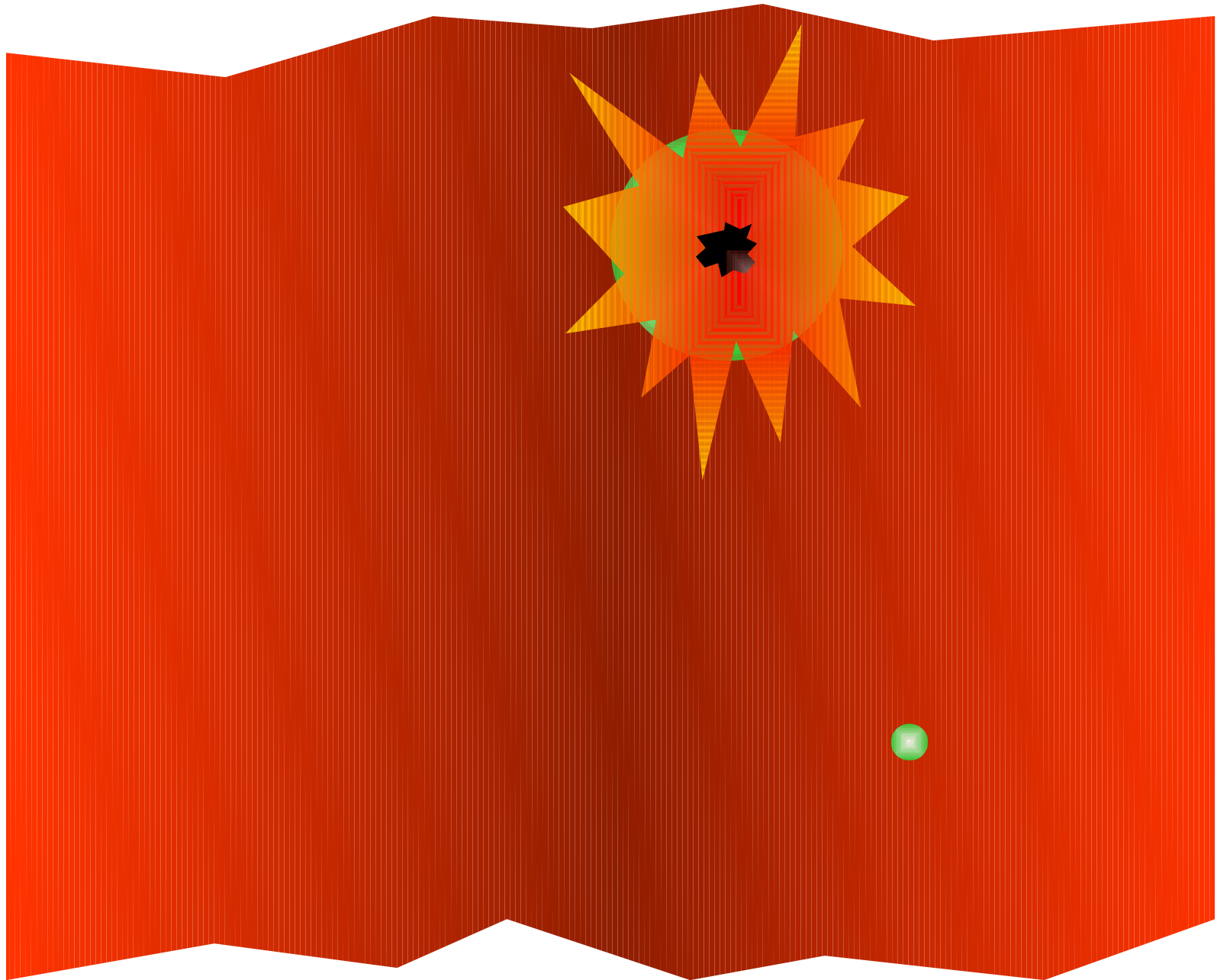

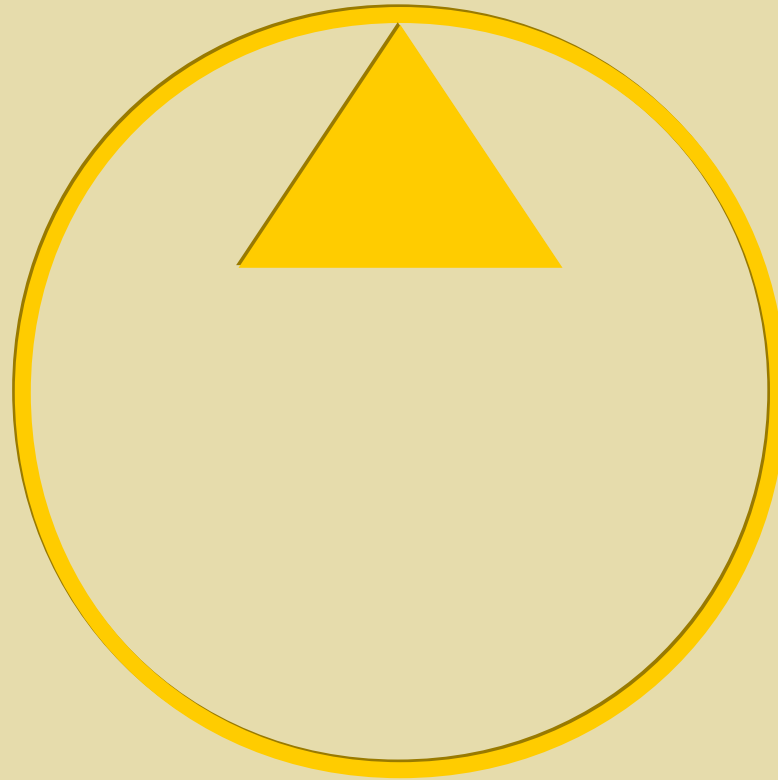

Steve Skinner, Eaton Hydraulics, Havant, UK

Copyright © Eaton Hydraulics 2000