

Monte Charge

Dossier Plans électriques.

| FOLIO | DESCRIPION | DATE VERSION |
|-------|----------------------------------|--------------|
| 01 | SCHEMA DE PUISSANCE | 22/10/2003 |
| 02 | SCHEMA DE COMMANDE | 22/10/2003 |
| 03 | COMMANDE VARIATEUR DIGIDRIVE | 22/10/2003 |
| 04 | SCHEMA DE SIGNALISATION | 22/10/2003 |
| 05 | CABLAGE GAINÉ | 22/10/2003 |
| 06 | CABLAGE BOITE A BOUTONS | 22/10/2003 |
| 07 | CABLAGE PENDANTIF COFFRET CABINE | 22/10/2003 |

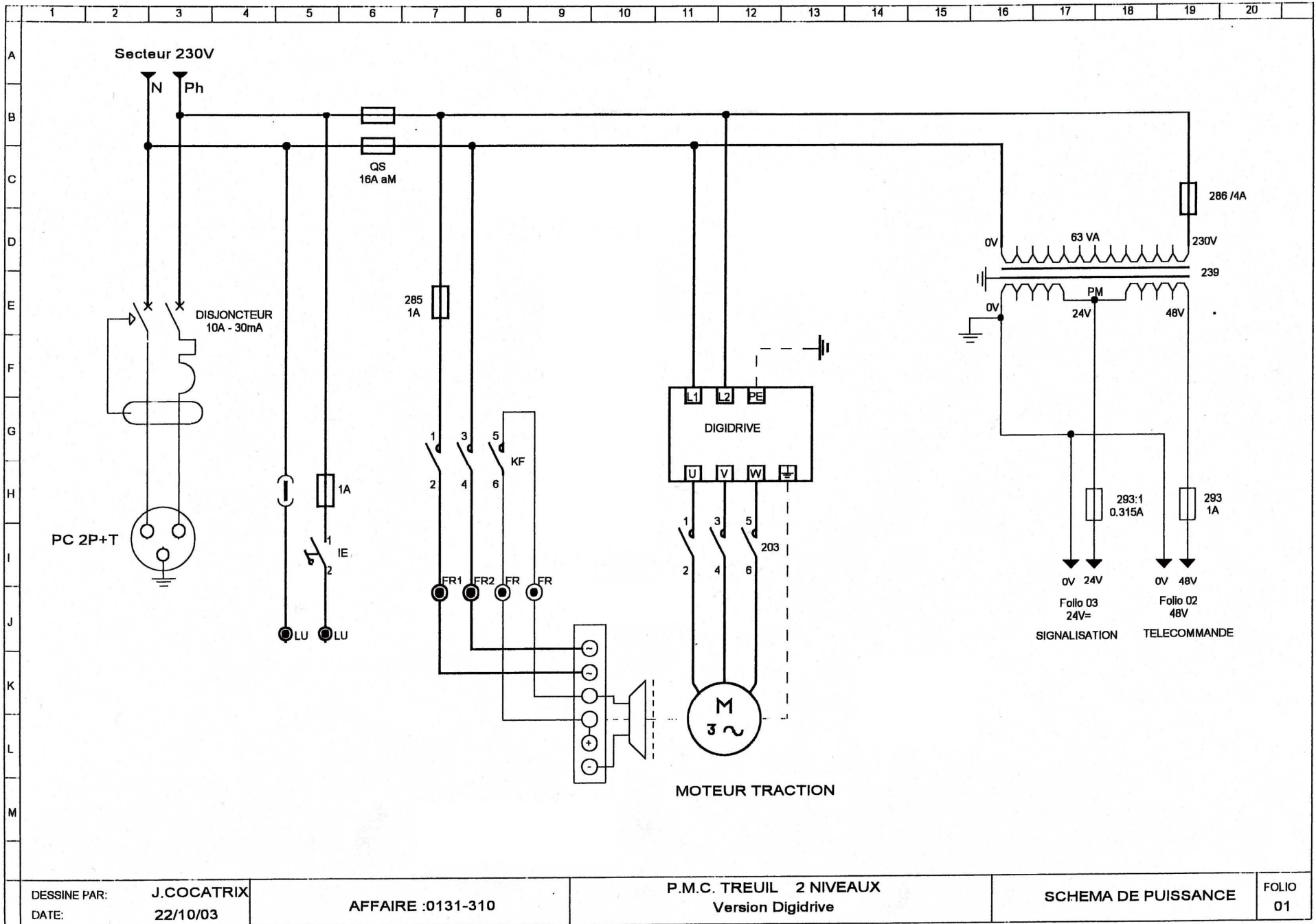

Monte Charge

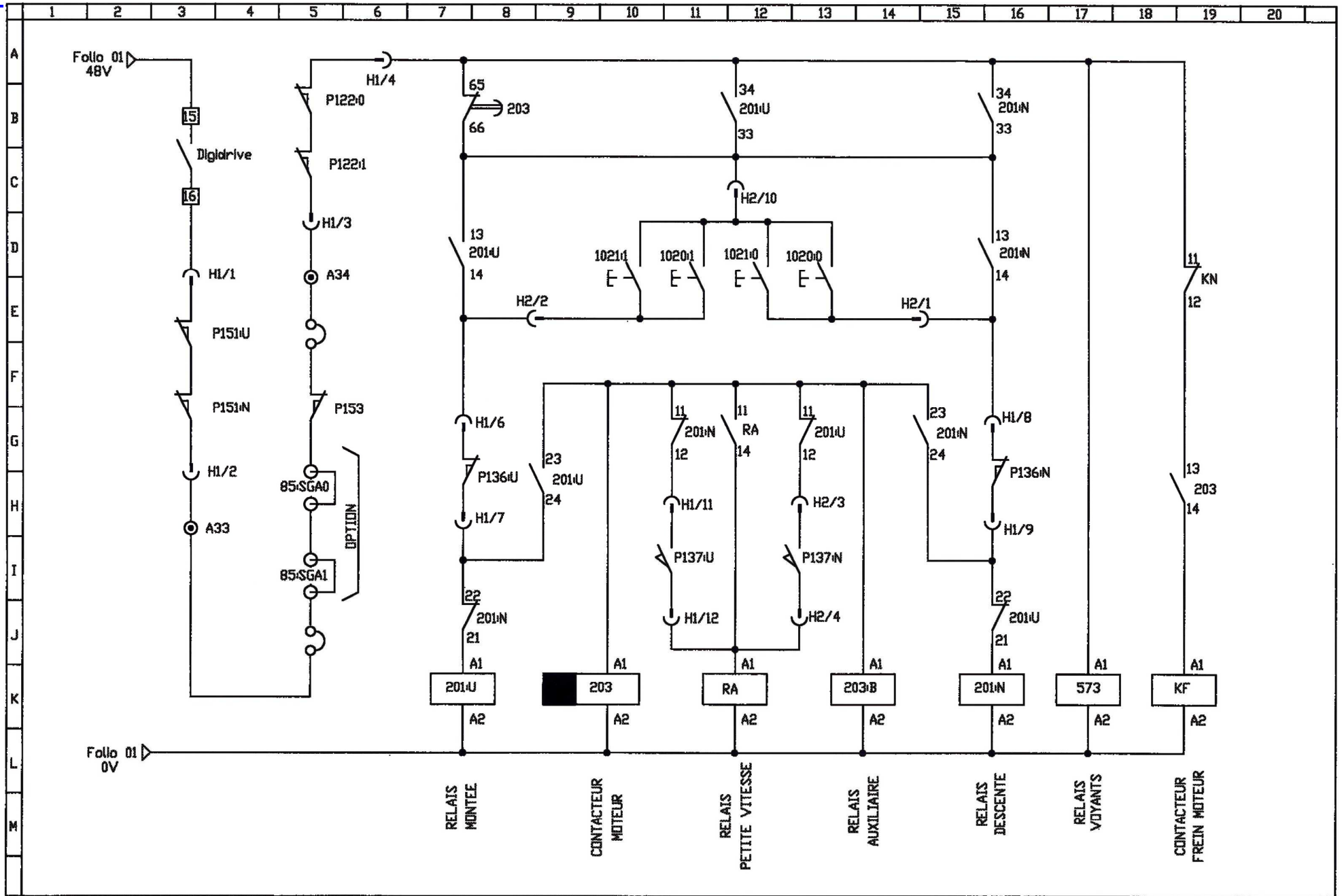

Monte Charge

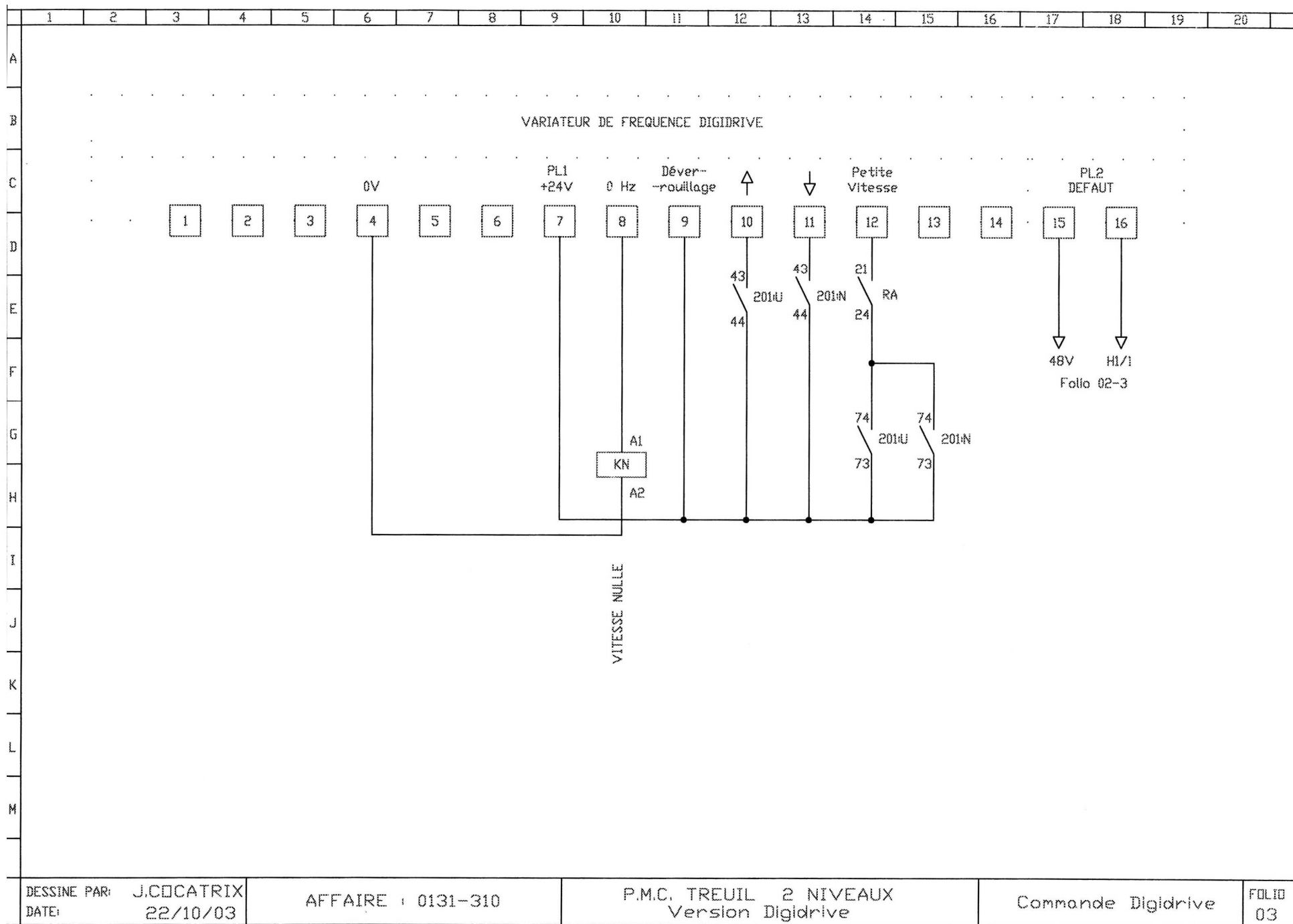

DESSINE PAR: J.COCATRIX
DATE: 22/10/03

AFFAIRE : 0131-310

P.M.C. TREUIL 2 NIVEAUX
Version Digidrive

Commande Digidrive

FOLIO
03

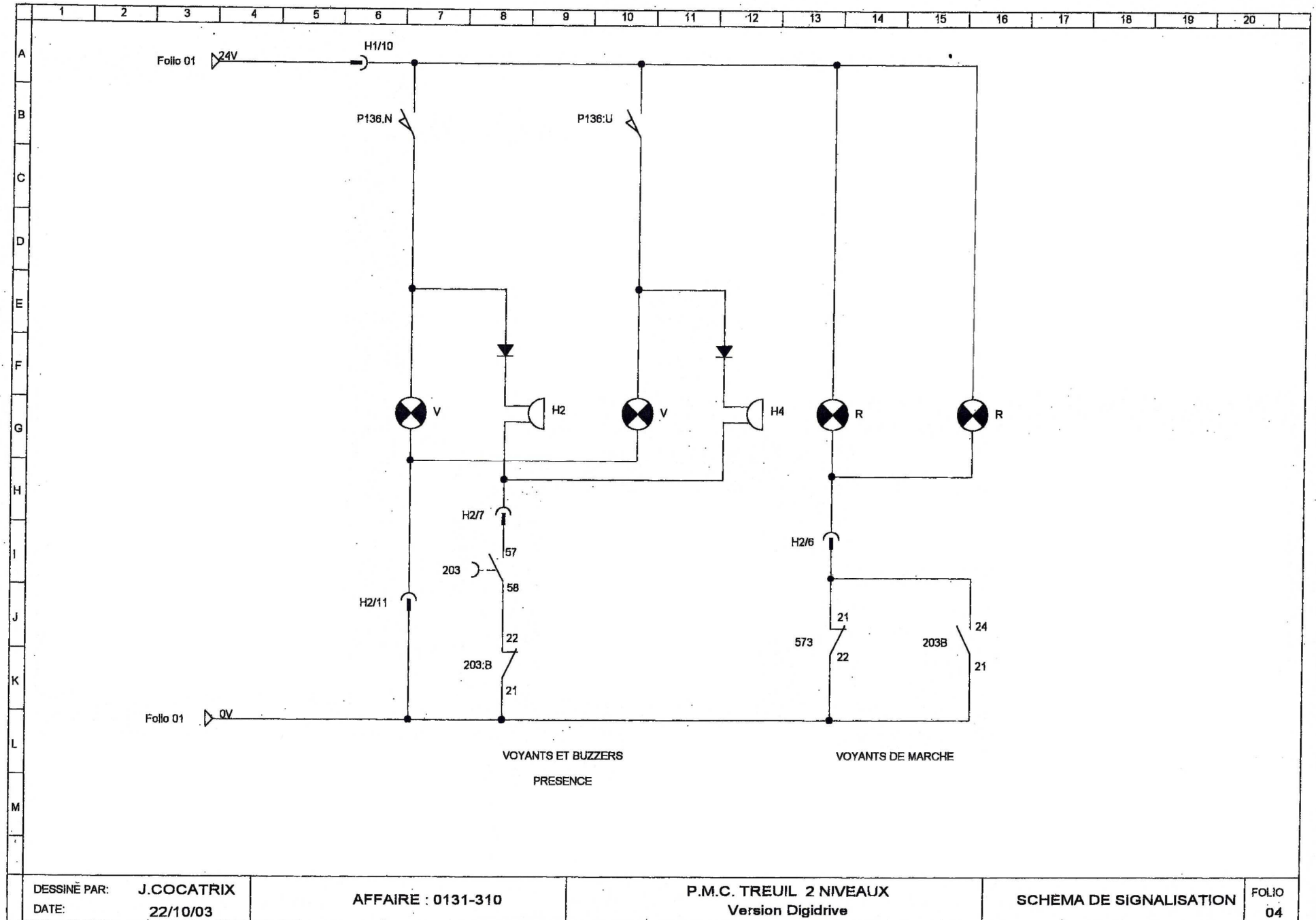

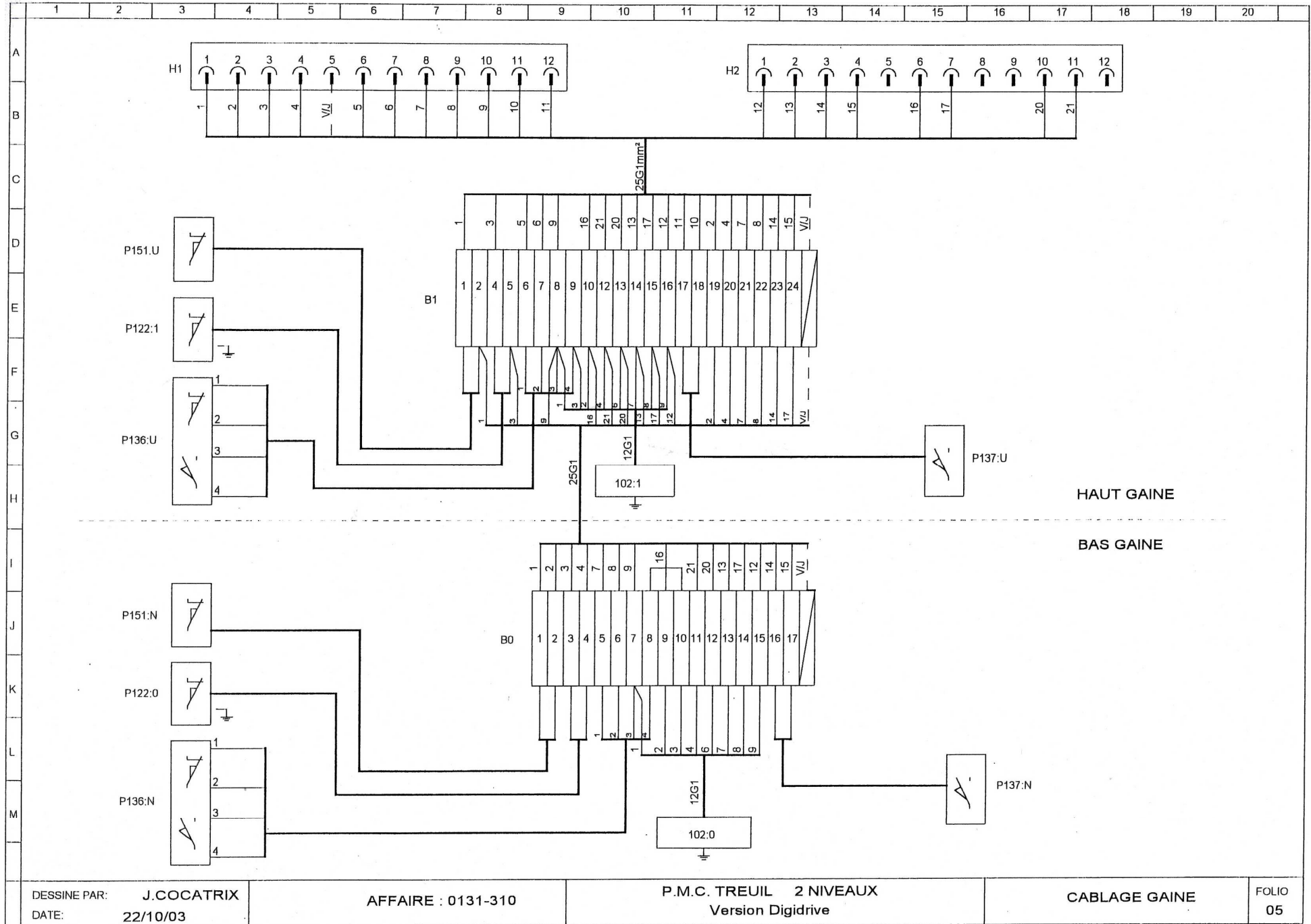

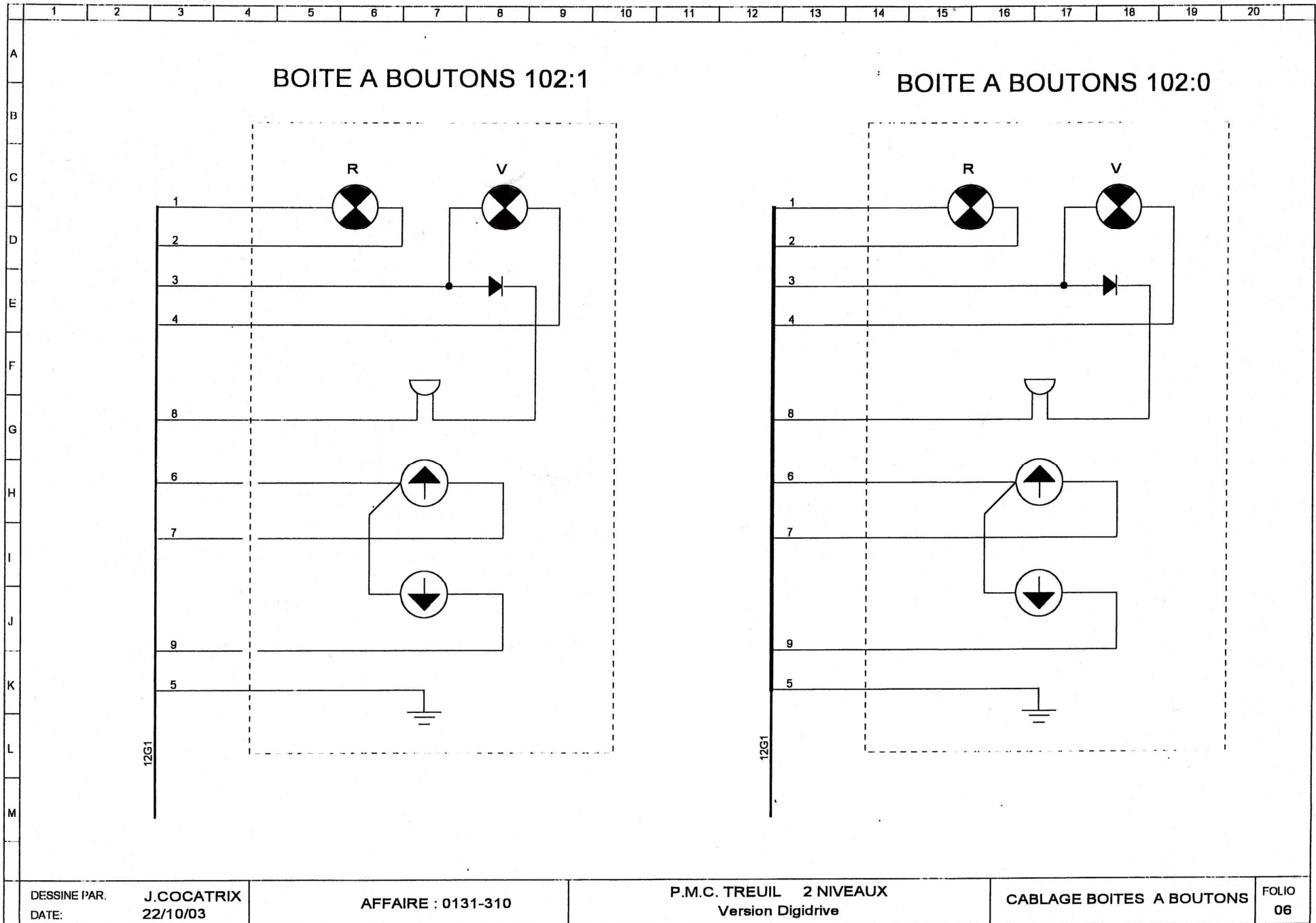

Monte Charge

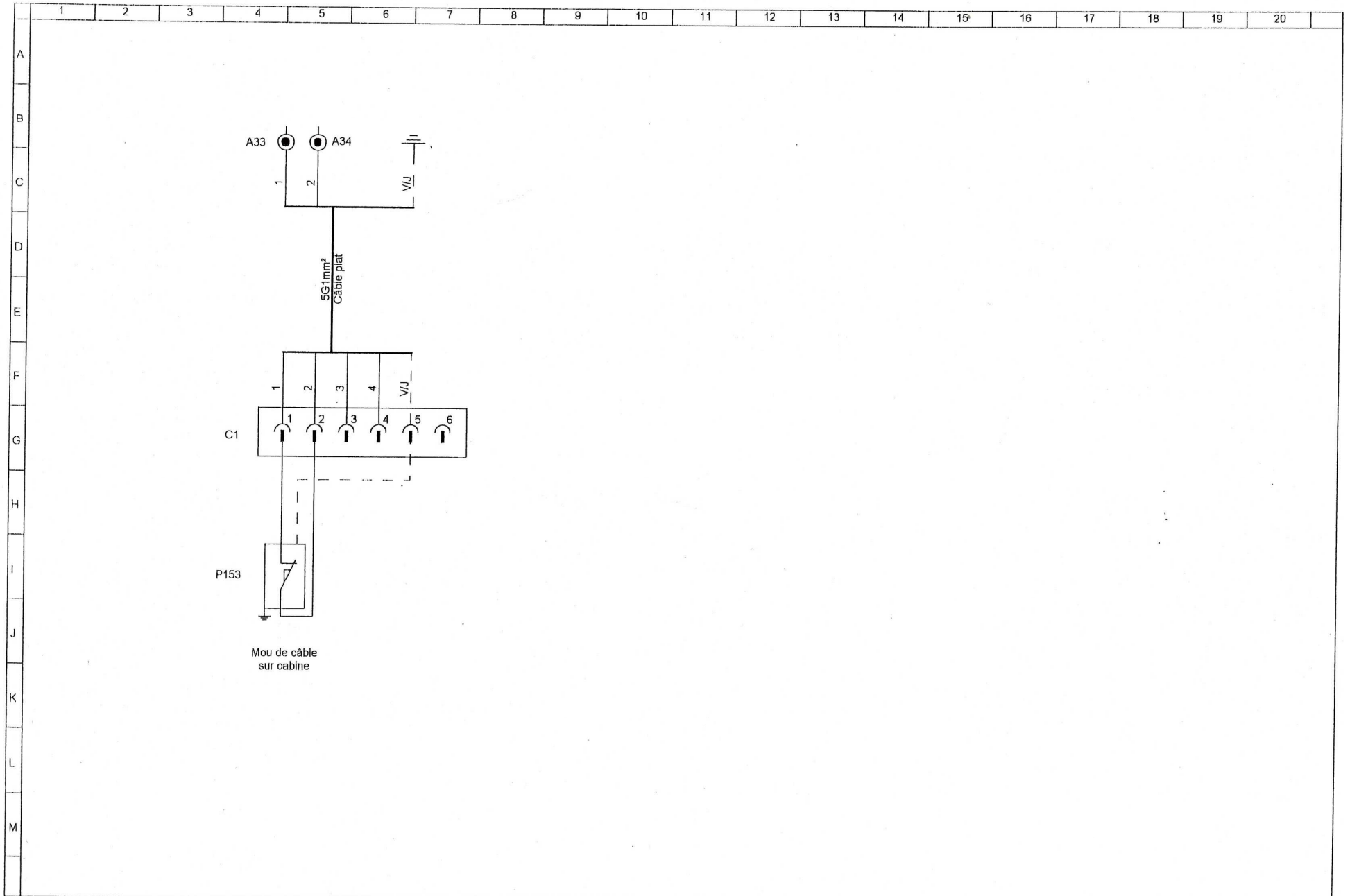

DESSINE PAR: J.COCATRIX
DATE: 22/10/03

AFFAIRE : 0131-310

P.M.C. TREUIL 2 NIVEAUX
Version Digidrive

CABLAGE PENDENTIF
COFFRET CABINE

FOLIO
07