

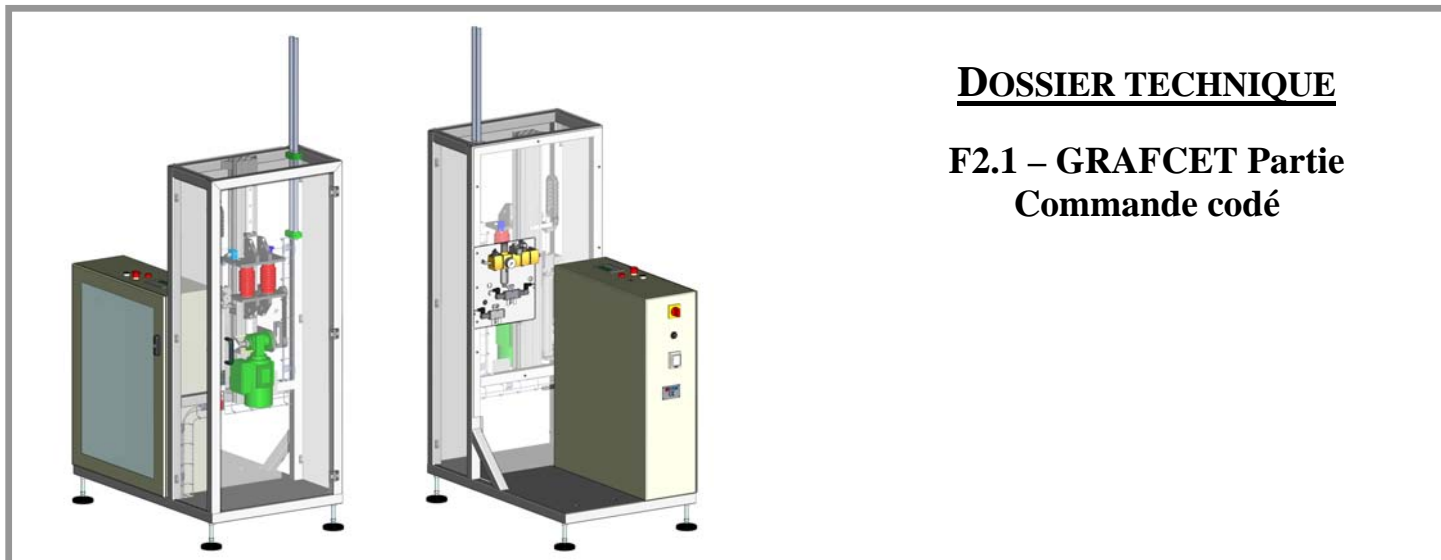

DOSSIER MACHINE

1	GRAFCET POINT DE VUE PARTIE COMMANDE CODE	1
1.1	GRAFCET DE SECURITE	1
1.2	GRAFCET DES MODES DE MARCHÉ	2
1.3	GRAFCET DE TACHE	3
1.3.1	Gestion des technologies	3
1.3.2	Version hydraulique	4



DOSSIER TECHNIQUE

F2.1 – GRAFCET Partie Commande codé

1 GRAF CET POINT DE VUE PARTIE COMMANDE CODE

1.1 GRAFCET de sécurité

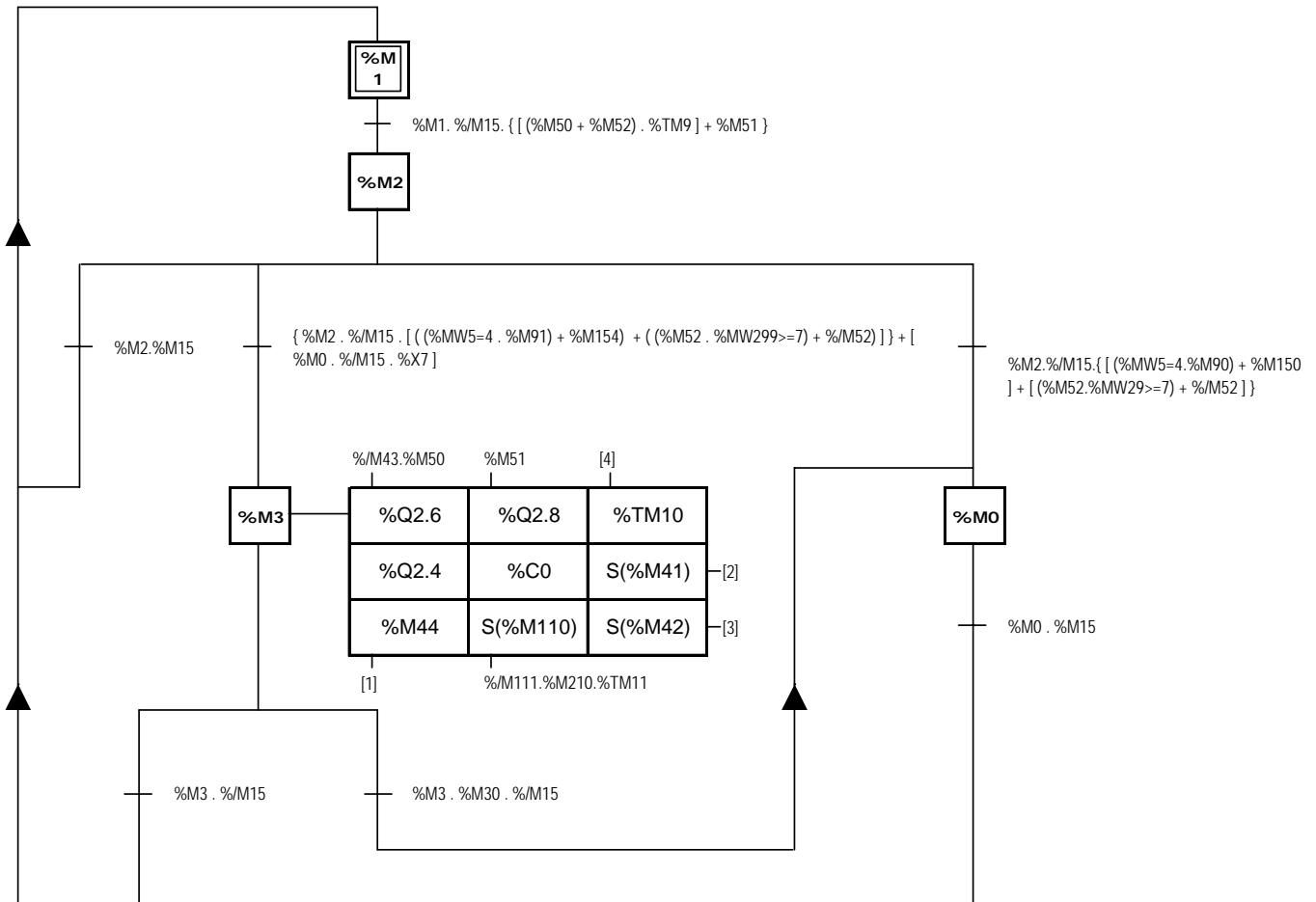

$$C.I. = [(\%M45 + \%I1.2) . \%M43 . (\%M50 + \%M52)] + [\%M51 . ((\%MW37 = \%MW33 . \%M3 . \%TM19.Q) + (\%MW33+5 >= \%MW37 . \%M0))]$$

$$\%M15 = \%I1.5 + \{ [\%M0 + \%M3] . [(\%I1.6 + \%I1.7 + \%M110 + \%M104 + \%M103 + \%M112) . (\%M50 + \%M52) + (\%M203 . \%M52)] \} + \{ \%M51 . [\%I1.9 + \%MW35 > 55 + \%I1.4] \}$$

$$[1] = [(\%M3 . \%M9 . \%M20) + \%M8] . \%S1 . \%M43$$

$$[2] = [(\%M3 . \%M9 . \%M20) + \%M8] . \%S1 . \%M44 . \%Q2.1 . \%Q2.2 . \%I1.2$$

$$[3] = [(\%M3 . \%M9 . \%M20) + \%M8] . \%S1 . \%M41$$

$$[4] = [(\%M3 . \%M9 . \%M20) + \%M8] . \%S1$$

1.3 GRAFCET de tâche

1.3.1 Gestion des technologies

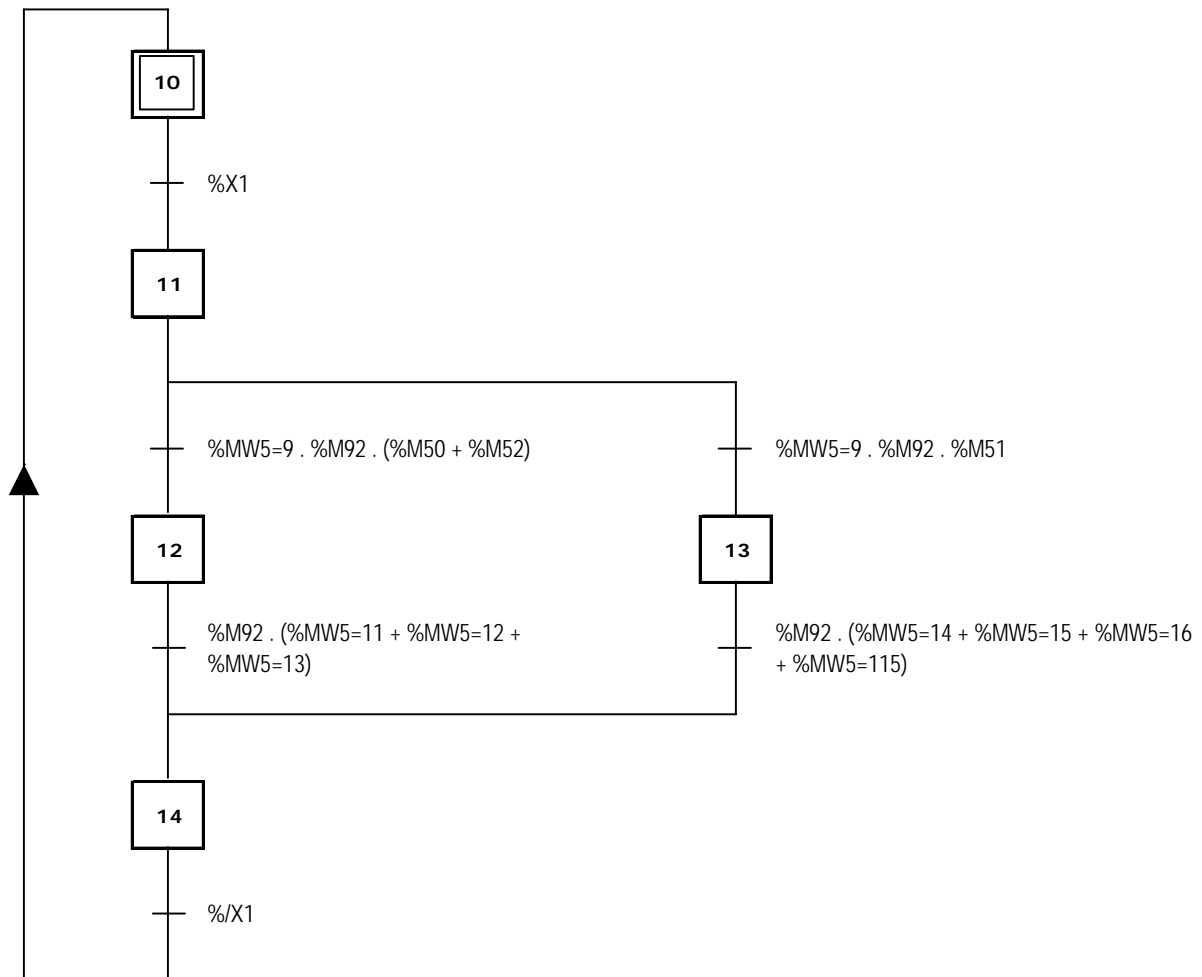

1.3.2 Version hydraulique

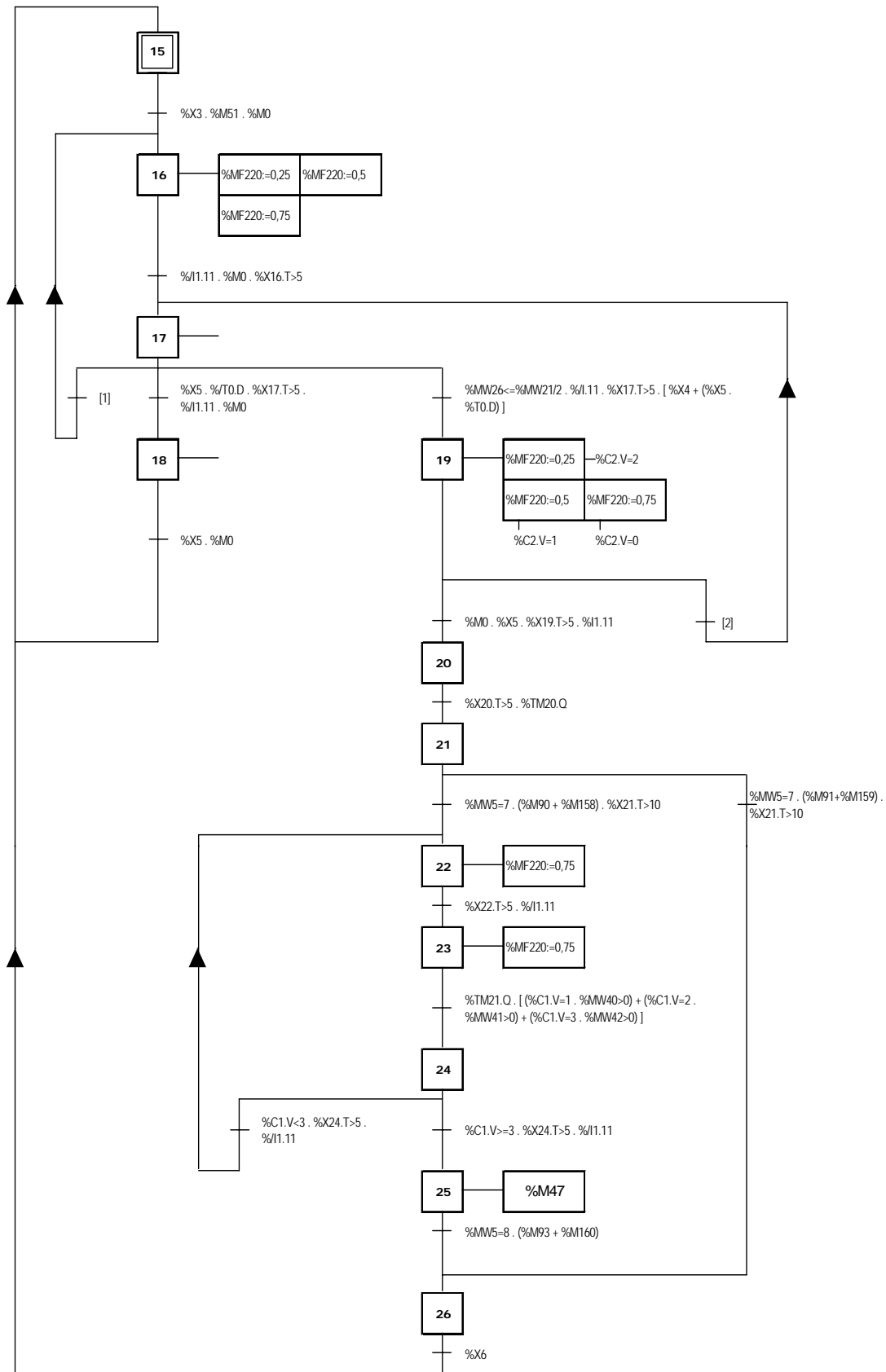

[1] = %MW26>%MW21/2 . %X4 . %I1.11 . %M0 . %X17.T>5

[2] = %M0 . %X4 . %X19.T>5 . %I1.11