

# Motors and Brakemotors

## Type BM (G) Brakes

OPERATING INSTRUCTIONS

09 793 77 US

### General

Every SEW-Eurodrive motor is thoroughly tested, checked, and properly packed prior to shipment. However, please check immediately upon arrival for shortage of parts or transit damage. Note the damage or shortage on the freight bill of lading and file a claim with the carrier. Also, notify SEW-Eurodrive of the shortage or damage.

### Installation

For motors mounted integrally to a gear unit, please refer to the Operating Instructions for Gearmotors and Gear Reducers for proper installation of the drive. The drive installation site should be selected to ensure:

- Ambient temperatures below 40°C (104°F).
- Unimpeded flow of air to the motor and variable speed units.
- Accessibility to gear unit, oil plugs.
- Adequate space for the removal of the brakemotor fangard for brake adjustment and maintenance.

The drive unit should be mounted on a flat, vibration damping, and torsionally rigid structure. The flatness tolerance of the supporting surface should not exceed:

For motor size 180 and smaller — 0.004 inch  
For motor size above 180 — 0.008 inch

Do not hammer on the shafts to install couplings, sheaves, etc. Hammering can cause brinelling of the bearings and a reduction in bearing life. We recommend heating the components to approximately 175°F and sliding them on. This will reduce possible damage to the bearings. In addition, there is a metric tapped hole in the center of the motor shaft that can be utilized with a tool to press on or remove the coupling, sheaves, etc.

The motor shaft diameters are metric and have tolerances as listed in the SEW-Eurodrive catalogs. Shaft couplings should be properly aligned to prevent vibration, coupling wear and premature failure of the shaft bearings.

Maximum Parallel Offset — 0.003 inch  
Maximum Angular Offset — 0.030°

To prevent the output shaft and bearings from being subjected to excessive loads, the maximum overhung loads, as shown in SEW-Eurodrive catalogs, should not be exceeded. Please consult our engineering department if the load may exceed the recommended figure given or where there are combined radial and axial loads. In such cases, the exact operating conditions must be stated including speed, direction of rotation, position, magnitude and direction of the external radial and axial loads being applied.

### Long Term Storage

If the motor must be stored for a long period of time without operating, the motor must be stored in a dry, protected area, and in the mounting position indicated on the unit nameplate. In order to ensure that the motor has not been damaged by moisture after a prolonged storage, the insulation resistance should be checked. An insulation tester with a measurement voltage of at least 500V (e.g. magneto generator) should be used for this purpose. The insulation resistance is sufficient if it has an ohmic

value of at least  $1000 \times V_N$  (e.g. at  $V_N = 230\text{VAC}$ :  $R_{\text{insul}} \geq 230000$  ohms = 0.23M ohms). If the measured value is smaller, the motor should be dried before use (for example, with hot air up to a maximum of 90°C or by resistance heating with an auxiliary AC voltage of 10% of  $V_N$  via an isolating transformer). Care should be taken to ensure that the motor is heated with not more than 20% of its rated current and that the rise in temperature is not more than 90°C. The drying procedure can be stopped when the insulation resistance has reached  $500000 = 0.5\text{M}$  ohms.

### Severe Duty Units

Severe Duty Units are indicated with the letters “-KS” at the end of the motor type on the motor nameplate. Severe Duty units include drain holes in the motor end bells and conduit box at the lowest points allowing condensation to drain out of the motor.

### CAUTION!

**The drain holes are installed for the mounting position listed on the gearbox nameplate. Installing a unit in a mounting position other than what is shown on the nameplate will reposition the condensation drain holes. As a result, the drain holes may not be located at the lowest point and may not allow water to drain. This can cause premature drive failure.**

### Electrical Connection

The motor must be installed and connected by a qualified electrician who is knowledgeable with the NEC article 430 and local regulations. He must make sure that the voltage and frequency of the electrical supply correspond with the data stamped on the motor nameplate before connecting the motor in accordance with the wiring diagram, which can be found in the terminal box. For brake connections, see the following pages.

At installation the electrician must make sure that the terminal block jumpers are positioned correctly and that all electrical connections including the ground connection are secure. In order to effectively protect the motor from overloads, appropriate motor protection must be provided. Fuses do not always provide adequate motor protection. For motors which are required to operate with a very high start-stop frequency, the overload heater type motor protection is insufficient. It is advisable in such applications to provide the motor with temperature sensors (thermistors) in the windings. Monitor the thermistors by means of an external trip device. In this way, the motor will be fully protected against practically all possible overloads.

When using motors outdoors or in washdown applications the cable entries into the terminal box must be directed downward to prevent water from entering the conduit box. The unused cable entries must be closed off properly.

### Lubrication and Maintenance

**WARNING! Always ensure equipment is secure and electrical power is off before removing or performing maintenance on the drive assembly.** The motor bearings are sealed and the grease content is adequate for the life of the bearing.



**SOUTHEAST MANUFACTURING & ASSEMBLY CENTER**  
1295 Spartanburg Highway/Lyman SC 29365  
(864) 439-7537 Fax: (864) 439-7830

**SOUTHWEST ASSEMBLY CENTER**  
3950 Platinum Way/Dallas TX 75237  
(214) 330-4824 Fax: (214) 330-4724

**MIDWEST ASSEMBLY CENTER**  
2001 West Main Street/Troy OH 45373  
(937) 335-0036 Fax: (937) 332-0038

**EAST COAST ASSEMBLY CENTER**  
200 High Hill Road/Bridgeport NJ 08014  
(856) 467-2277 Fax: (856) 845-3179

**WEST COAST ASSEMBLY CENTER**  
30599 San Antonio Road/Hayward CA 94544  
(510) 487-3560 Fax: (510) 487-6381



## Brake Coil Resistance

Motor Frame		DT71-80	DT80	DT90-100	DT100	DV112-132S	DV132M-160M	DV160L-225
Brake Size		BM(G)05	BM(G)1	BM(G)2	BM(G)4	BM(G)8	BM15	BM30/31/32/62
Brake Torque (lb-ft)		0.89 - 3.7	4.4 - 7.4	3.7 - 14.8	17.7 - 29.5	7.00 - 55.3	18.4 - 110.6	36.9 - 442.5
BRAKE VOLTAGE		$R_B(\Omega)$	$R_B(\Omega)$	$R_B(\Omega)$	$R_B(\Omega)$	$R_B(\Omega)$	$R_B(\Omega)$	$R_B(\Omega)$
AC (to rectifier $V_B$ )	DC	$R_T(\Omega)$	$R_T(\Omega)$	$R_T(\Omega)$	$R_T(\Omega)$	$R_T(\Omega)$	$R_T(\Omega)$	$R_T(\Omega)$
—	24	4.4 13.4	3.9 12.1	3.4 10.2	2.7 8.2	1.4 7.5	0.8 5.0	0.67 5.0
105-116	48	17.6 53.4	15.6 48.1	13.6 40.5	10.9 32.7	5.7 29.8	3.1 20.1	2.2 16.8
186-207	80	55.6 169	49.5 152	42.9 128	34.5 103	17.9 94.2	9.8 63.5	7.1 53.0
208-233	96	70.0 213	62.3 192	54.0 161	43.4 130	22.5 119	12.4 80.0	8.9 66.7
330-369	147	176 534	157 481	136 405	109 327	56.5 298	31.1 201	22.3 168
370-414	167	221 672	197 606	171 510	137 411	71.2 375	39.2 253	28.1 211
415-464	185	279 846	248 762	215 643	173 518	89.6 472	49.3 318	35.4 266
465-522	208	351 1066	312 960	271 809	218 652	113 594	62.1 401	44.6 334

Voltage AC - The voltage shown is the nameplate AC brake voltage supplied to the brake rectifier.

DC - The voltage shown is the effective DC voltage required by the brake coil. The measured voltage from the rectifier will be 10-20% lower than that shown.

Brake Coil Resistance - values must be measured with the brake coil disconnected from the rectifier.

$R_B$  - Accelerator coil resistance in  $\Omega$ , measured from the red to the white brake coil wire at 20° C.

$R_T$  - Fractional coil resistance in  $\Omega$ , measured from the white to the blue brake coil wire at 20° C.

## Brake Connection (AC Voltage)

SEW-Eurodrive motor brakes can be connected in a number of different ways. In order to connect the brake for each application, it is important to refer to the data on the motor nameplate that describes the brake system. The brake fields are: brake voltage, brake torque and brake control.

This operating instruction covers AC brake voltages with the following brake control components. If the brake voltage is DC, or if the brake control components differ from those listed below, an additional operating instruction must be consulted for connection information.

SEW-Eurodrive fail-safe mechanical brakes are DC controlled. Standardly, a brake rectifier (halfwave) is provided to convert the AC line voltage to the DC voltage required to drive the brake. 24VDC brakes do not include a rectifier. When voltage ( $V_B$ ) is applied to the brake, it will release. When voltage ( $V_B$ ) is removed from the brake, it will set. The brake rectifier can be wired either for normal brake reaction time (setting, stopping) or fast brake reaction time. The fast brake reaction will set the brake more quickly which will provide a shorter and more repeatable stopping distance. There are two basic types of brake rectifiers, BG and

Brake Control (Rectifier)	Part Number
BG1.5	825 384 6
BG3.0	825 386 2
BGE1.5	825 385 4
BGE3.0	825 387 0

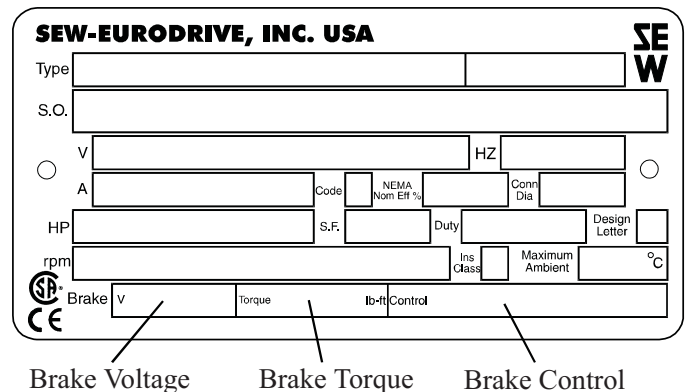

BGE. The BG brake rectifier is standard on motor sizes DT71 - DT100. The BGE rectifier is standard on motor sizes DV112 - DV225. The BGE rectifier can be ordered with motor sizes DT71 - DT100 and will provide faster brake release times allowing the motor to cycle more frequently.

The wiring diagrams for brake connections are located on the inside of the motor conduit box lid. The brake will release and allow the motor to rotate when the nameplate AC brake voltage  $V_B$  is supplied to the brake rectifier terminals. There are certain cases where the brake rectifier can receive its voltage from the motor's terminal block, meaning that when power is applied to the motor it will simultaneously release the brake and start the motor. See page 3 for this description.

## Brake Voltage Supplied from the Motor

There are specific instances when the brake voltage can be tapped from the motor's terminal block. The advantage of brake systems wired in this way is when power is applied to the motor, the brake releases, (requiring no additional brake supply power wiring). The brake can be wired to the motor terminal block under the following conditions: a single speed motor; the motor is started and run across the line (i.e., no inverter or electronic soft start). The connections shown on this page are for normal brake reaction time. For rapid brake reaction time, incorporate the contact as shown on the brake diagram located on the inside of the motor conduit box lid.

### Brake Motor Connection

#### Single Speed Dual Voltage - $\Delta\Delta/\Delta$ Connection Diagram DT72

#### Example Motor Voltages:

230 $\Delta\Delta$ /460 $\Delta$  Volts - 60 Hz

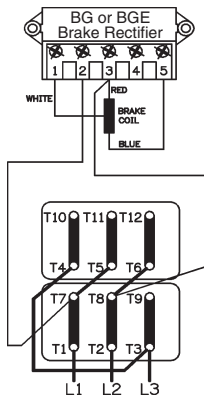

Motor wired for low voltage.  
Brake voltage matches low motor voltage.  
Example: 230/460V Motor  
Motor wired 230V  
Brake voltage 230V

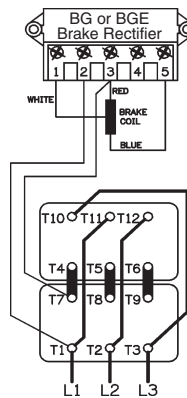

Motor wired for high voltage.  
Brake voltage matches low motor voltage.  
Example: 230/460V Motor  
Motor wired 460V  
Brake voltage 230V

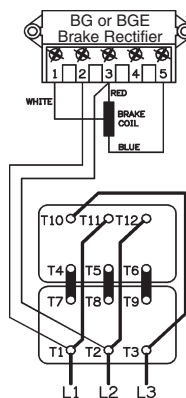

Motor wired for high voltage.  
Brake voltage matches high motor voltage.  
Example: 230/460V Motor  
Motor wired 460V  
Brake voltage 460V

### Brake Motor Connection

#### Single Speed Dual Voltage - YY/Y Connection Diagram DT79

#### Example Motor Voltages:

230YY/460Y Volts - 60 Hz

200YY/400Y Volts - 50 Hz

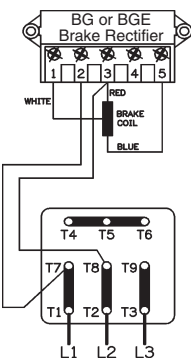

Motor wired for low voltage.  
Brake voltage matches low motor voltage.  
Example: 230/460V Motor  
Motor wired 230V  
Brake voltage 230V

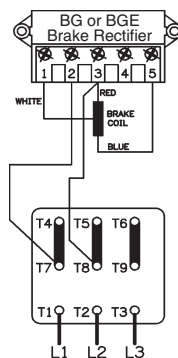

Motor wired for high voltage.  
Brake voltage matches low motor voltage.  
Example: 230/460V Motor  
Motor wired 460V  
Brake voltage 230V

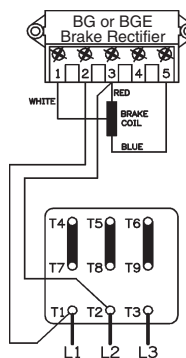

Motor wired for high voltage.  
Brake voltage matches high motor voltage.  
Example: 230/460V Motor  
Motor wired 460V  
Brake voltage 460V

### Brake Motor Connection

#### Single Speed Dual Voltage - $\Delta/Y$ Connection Diagram DT13

#### Examples Motor Voltages:

200 $\Delta$ /346Y Volts - 60 Hz

330 $\Delta$ /575Y Volts - 60 Hz

220 $\Delta$ /380Y Volts - 50 Hz

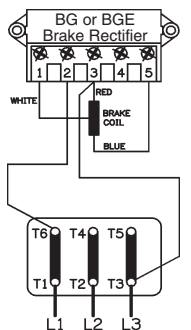

Motor wired for low voltage.  
Brake voltage matches low motor voltage.  
Example: 200/346V Motor  
Motor wired 200V  
Brake voltage 200V

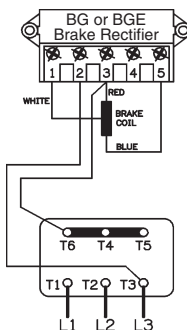

Motor wired for high voltage.  
Brake voltage matches low motor voltage.  
Example: 220/380V Motor  
Motor wired 380V  
Brake voltage 220V

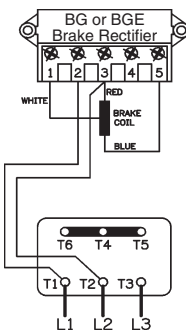

Motor wired for high voltage.  
Brake voltage matches high motor voltage.  
Example: 220/380V Motor  
Motor wired 380V  
Brake voltage 380V

## Re-adjusting the Brake Air Gap

A properly adjusted brake air gap is critical for correct operation. The following table indicates the required air gap measurement.

Motor Size	Brake Size	Air Gap
DT71 - DT100	BM(G)05 - BM(G)4	0.010"-0.024" (0.25-0.6 mm)
DV112 - DV225	BM(G)8 - BM31	0.012"-0.047" (0.3-1.2 mm)
DV180-DV225	BM32-BM62 Double Disc	0.016"-0.047" (0.4-1.2 mm)

Prolonged use of the brake will wear the brake disc lining. This wear increases the air gap. When the air gap approaches its maximum value, the brake must be re-adjusted. To re-adjust the brake, follow the procedure below.

1. Remove the fan cover (14), fan snapping, fan (17), rubber seal (2), and any accessories at the fan end.
2. Insert a feeler gauge between the brake coil body (21) and the stationary disc (22), tighten the adjusting nuts (19) until the minimum value for the air gap is reached equally around the brake. With motor size 160L and up (brakes BM30 to BM62) first screw the threaded bushings (24) into the endshield. After setting the air gap, lock the bushings (24) against the coil body.
3. Ensure a play of 0.06" to 0.08" (1.5 to 2 mm) in the releasing arm. See "THE HAND RELEASE MECHANISM."

## Replacement of the Brake Disc (26)

Extended operation of the brake may wear the brake disc (26) beyond acceptable limits. The thickness of the brake disc can be measured to determine if this has occurred.

Motor Size	Brake Size	Min. Disc (26) Thickness
DT71 - DT100	BM05 - BM4	0.354" (9mm)
DV112 - DV225	BM8 - BM62	0.394" (10mm)

If the brake disc (26) is worn below the measurement given, it must be replaced. If the thickness is greater than the specification above, the brake disc is still usable and the brake can be re-adjusted.

## The Hand Release Mechanism

Most of our brakes are supplied with a hand-operated release lever. This allows opening of the brake without applying power, allowing for adjustments on the driven machinery.

There are two brake release mechanisms available:

The "BMHR" (4) type requires a lever to be inserted into the release arm. To open the brake, pull the lever away from the motor. It will re-engage automatically, once the lever is released. The lever, when not used, is attached to the motor's cooling fins with clamps.

The screw-type "BMHF" (5) arrangement requires a hexagon key which, when turned clockwise, opens the brake.

Since the stationary disc (22) will move away from the coil body during the brake's operation, it is vital that there is free play (floating clearance) on the release arm of 0.060"-0.080" (1.5-2.0 mm). The springs (11) should be placed between the arm (7) and the nuts (12) to eliminate noise.

**The brake release mechanism is not used to change the brake's torque setting. There must always be clearance on the lever.**

## Troubleshooting

### Fault: Motor does not run

1. Check the motor and brake wiring for damage and proper connection.

2. At the motor, measure the line voltage, line current and motor resistance of all three phases.
3. If all three phases read a similar current value the following conditions may exist:

- The motor may be blocked by either an excessive external load, or problems in the reducer or the brake. In both cases, the motor should draw locked rotor (in-rush) current. Consult SEW-Eurodrive catalogs for these values. Release the brake mechanically, reset the air gap if needed, or disconnect the load from the output shaft.
  - If the brake is at fault electrically see #4 below.
  - If the current differs significantly from the rated locked rotor current, the motor is either an incorrect voltage, or it is jumpered for the wrong voltage.
4. If the brake can be released mechanically, but does not respond to voltage, check the brake for electrical problems.
    - Make sure the wiring is according to the instructions. Pay special attention to the brake voltage.
    - Energize the brake circuit and measure the AC voltage on the rectifier terminals 2 and 3 (BG/BGE rectifiers). The measured voltage should correspond to the nameplate inscription: "Brake V."
    - Measure the DC voltage across terminals 3 and 5 of the brake rectifier which should be about 35% to 45% of the previously measured AC voltage.
    - If there is no fault found to this point, measure the resistance of the brake coils. Disconnect the coil from the rectifier for this measurement. See the table on Page 2 for the brake coil resistance values.
    - Measure the resistance of each brake coil lead to the brake coil body. This test should show an open circuit. If a short is found, the brake coil is damaged.

If the results of all these checks (electrical connection, mechanical checks and adjustments, and electrical tests) indicate that the brake should work, then the most likely cause of the brake's failure to release is a damaged brake rectifier.

### Fault: Brake stopping time is too slow

If the brake has been operating well for some time and a gradual increase in stopping time has occurred, the release arm may have come in contact with the coil body. Verify that the brake release arm end play is correct, and check for excessive brake disc wear, (see previous instructions).

If the brake has been in operation for some time, and the stopping has become erratic, dust accumulation around the stationary disc guides may be the cause. Remove the brake's rubber sealing collar and clean with an air hose.

If the application is new, check the brake's wiring and air gap. If the brake is not wired for fast response, then changing the brake wiring to fast response will decrease the stopping time. Vertical motion and indexing applications may also require the fast response connection. Increasing the brake's torque may remedy the situation, but will also increase stress on the transmission.

On applications requiring excessive brake work, the lining's surface may become glazed due to extreme heat. The application of a BGE rectifier will improve this situation dramatically. BGE rectifiers are standard equipment on motors size DV 112 - DV225, but optional on the smaller sizes DT71-DT100. Contact SEW-Eurodrive for more information.

# BM(G) Brake Cross Section and Exploded Views

## BM(G) 05 - BM 15

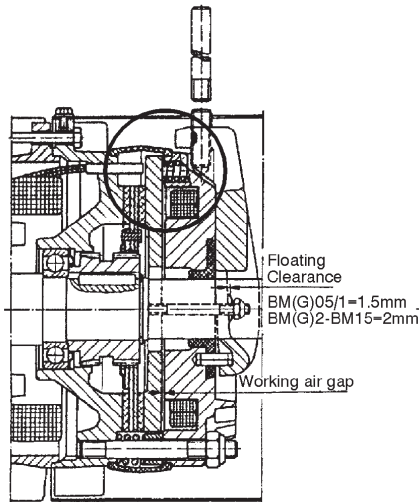

## BM 30/31

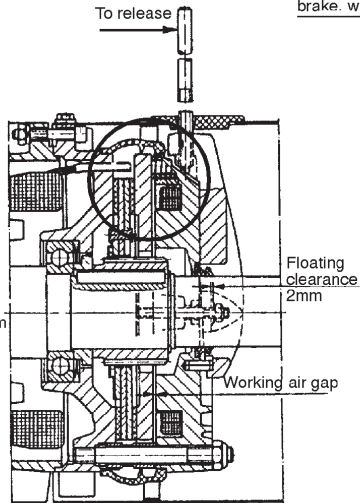

## BM 32/62

Hand lever for manually disengaging the brake. will re-engage itself when released

Manual brake release screw for fixing brake in the dis-engaged position

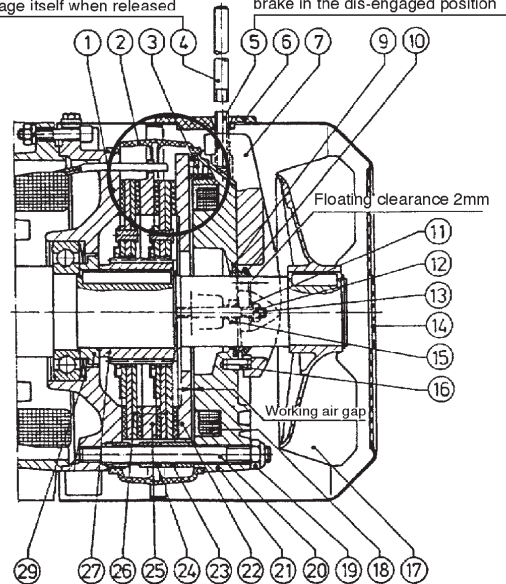

- (1) Brake end shield
- (2) Rubber sealing collar
- (3) Braking springs
- (4) Hand release lever
- (5) Releasing screw
- (6) Closing plate
- (7) Release arm
- (9) Sealing ring
- (10) V-ring
- (11) Conical spring
- (12) Release
- (13) Stud
- (14) Fanguard
- (15) Grommet

- (16) Dowel pin
- (17) Fan
- (18) N/A
- (19) Brake adjustment nut
- (20) Retaining stud
- (21) Brake coil body
- (22) Stationary disc
- (23) Pressure ring
- (24) Setting sleeve
- (25) Dual brake pad stationary disc
- (26) Brake disc complete
- (27) Carrier
- (29) Cup Spring

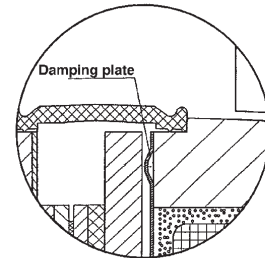

## Exploded view of the BM and BMG single-disk brake (motor sizes 71-160M)

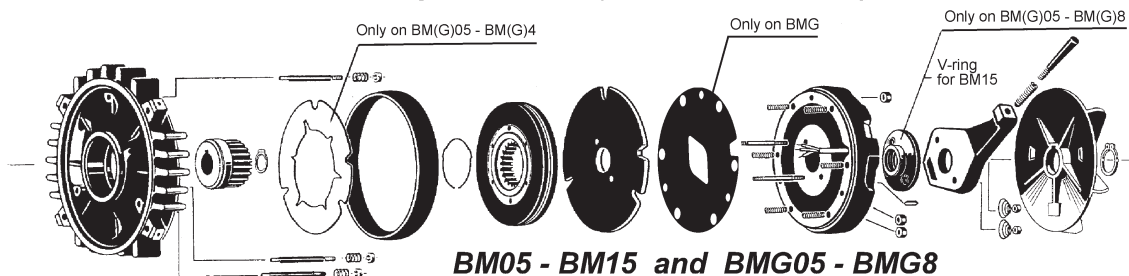

## Exploded view of the BM single-disk and double-disk brake (motor sizes 160L-225)

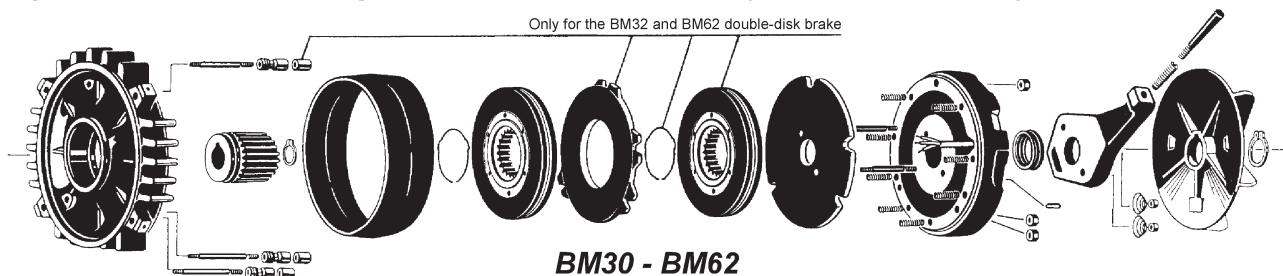

## Troubleshooting Chart

PROBLEM	CAUSE	REMEDY
Motor Overheats (Check temperature with instrumentation)	Motor not connected for proper supply voltage	Check connection diagram on conduit box cover and correct the wiring.
	Supply voltage varies outside the allowable tolerance causing an undervoltage or overvoltage condition.	Assure correct supply voltage.
	Insufficient cooling air volume due to: a. Low frequency operation on variable frequency drive. b. Obstructed air flow.	Increase air flow: a. Continuous running auxiliary fan. b. Ensure unobstructed air flow.
	Ambient temperature is too high.	Ensure cool air gets to the motor. Ducting may be required.
	Overload at rated voltage. Unit will draw current in excess of nameplate rating and run below rated speed.	Select a larger unit.
	Motor's allowable duty cycle is exceeded (too many starts per hour required).	The problem may or may not be solved with a larger motor. Contact SEW-Eurodrive.
	Single phasing due to break or loose connection in supply line or blown fuse.	Repair supply lines. Replace fuses.
Motor does not run.	Blown fuse.	Determine and correct cause of failure and replace fuse.
	Motor protection device activated.	Reset protective device. Identify and correct cause for device activation.
	Motor protection device faulty or will not reset.	Check protection device for faults.
Motor will not start or starts sluggishly.	Motor not connected for proper voltage.	Check connection diagram in conduit box cover and correct the wiring.
	Large voltage and/or frequency fluctuation at starting.	Ensure stable power supply.
For reduced voltage starting, motor will not start in Star Connection but will start in Delta connection.	Insufficient torque in Star Connection.	Start motor directly in Delta Connection if possible. Otherwise use a larger motor.
	Faulty contact in Star/Delta starter.	Correct fault condition.
Motor hums and draws high current.	Faulty or defective winding.	Have motor repaired by qualified service shop.
	Rotor dragging.	
Fuses blow or motor overcurrent protection trips immediately.	Short circuit in power supply conductors or in the motor.	Correct the fault condition.
	Motor has ground fault or winding to winding short circuit.	Have motor repaired by qualified service shop.
	Motor improperly connected.	Check connection diagram in conduit box cover and correct the wiring.
Motor runs in wrong direction.	Motor supply leads misconnected.	Switch two supply leads.

Note: If, after proceeding through the Troubleshooting Chart, the motor is found to be defective, contact your nearest SEW-Eurodrive Assembly Center for warranty assistance or replacement parts.